

TACT KNOWLEDGE

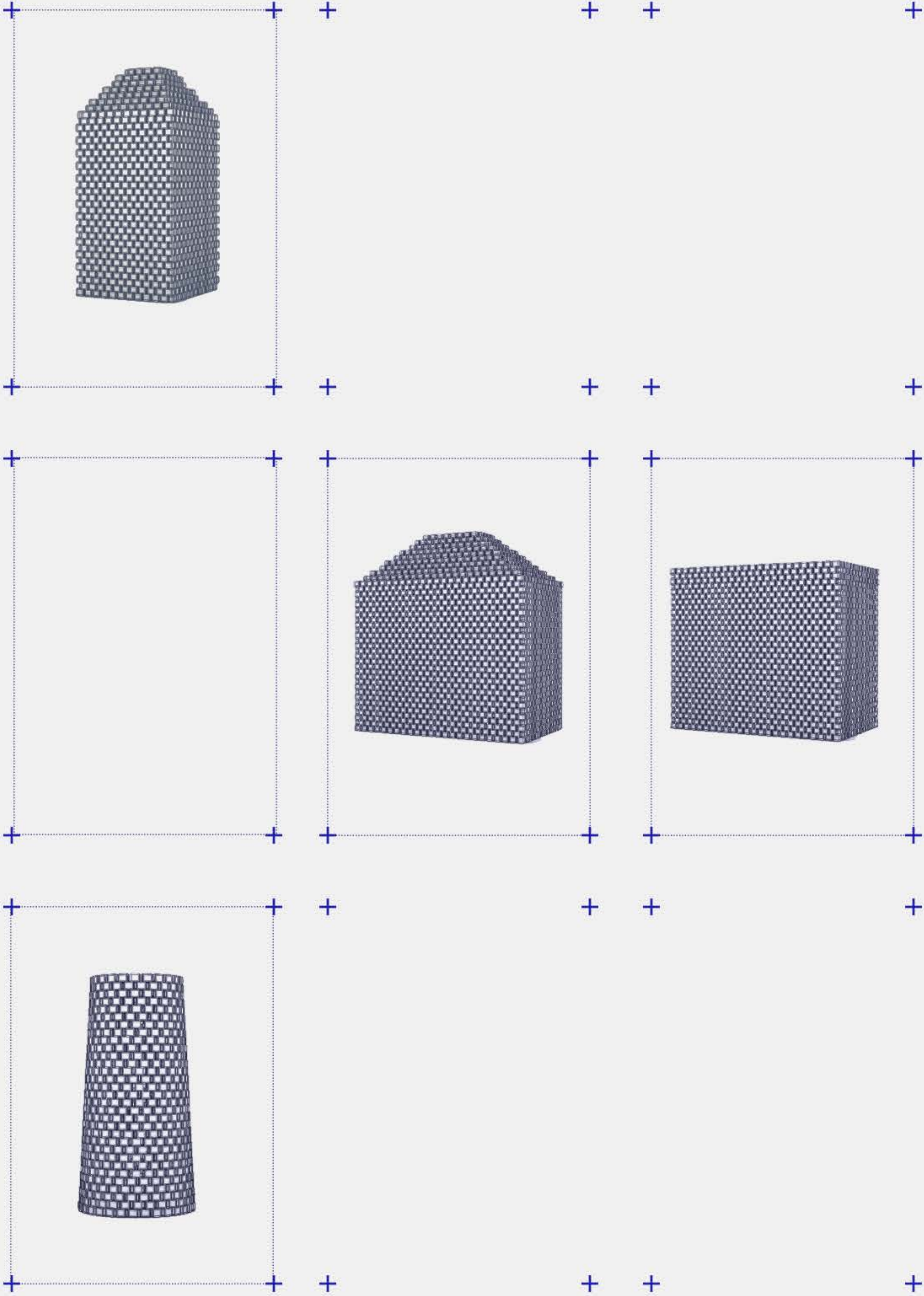

TANNOUR تنور
SOAP ARCHITECTURE FROM ALEPPO TO NABLUS

WESAM AL ASALI | NADI ABUSAADA

+ SOAP FACTORIES IN ALEPPO AND NABLUS +

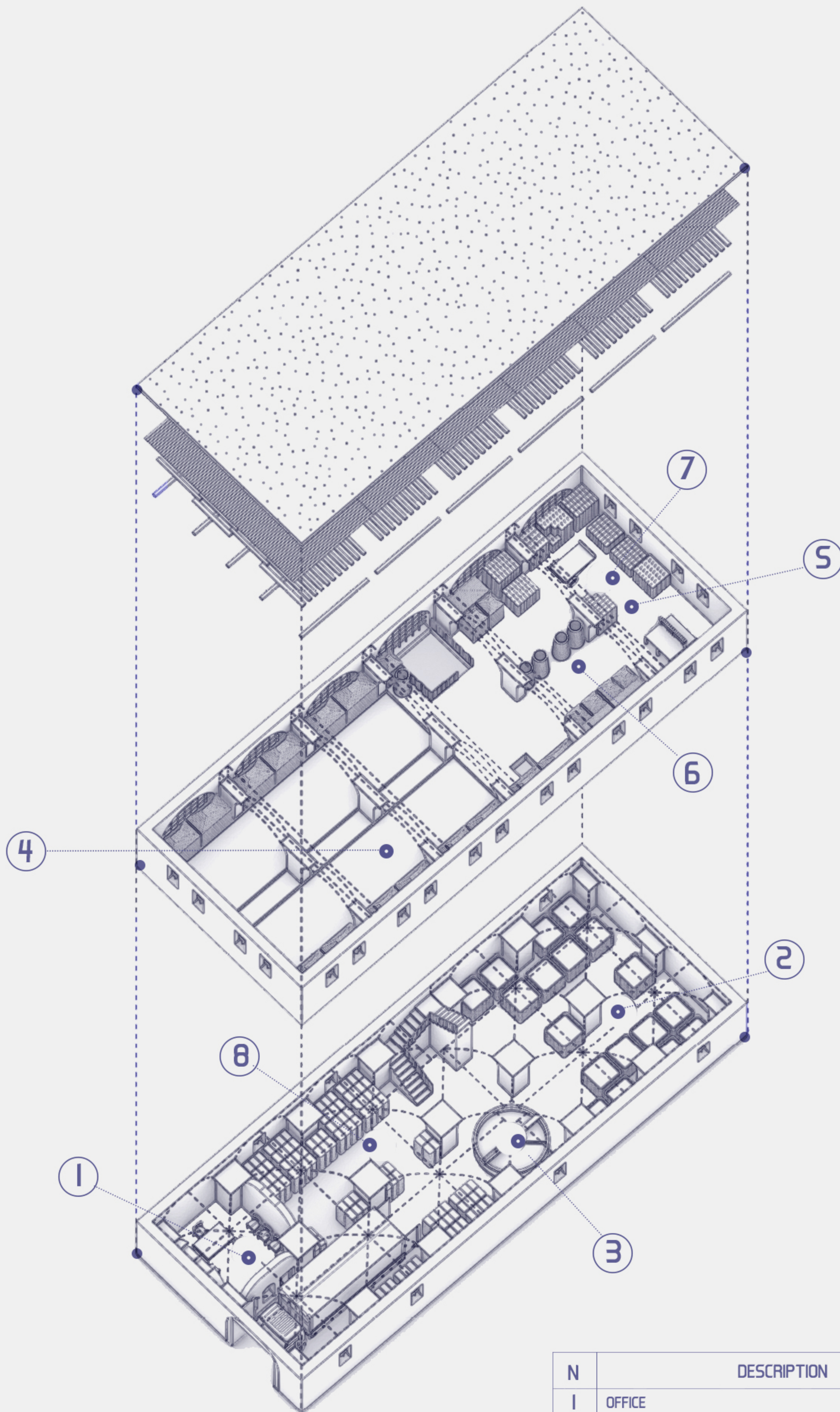

N	DESCRIPTION
1	OFFICE
2	STORAGE SPACE
3	COOKING SPACE
4	PREPARATION SPACE
5	ALTERNATIVE SPACE
6	DRYING SPACE
7	PACKAGING SPACE
8	EXPORTING SPACE

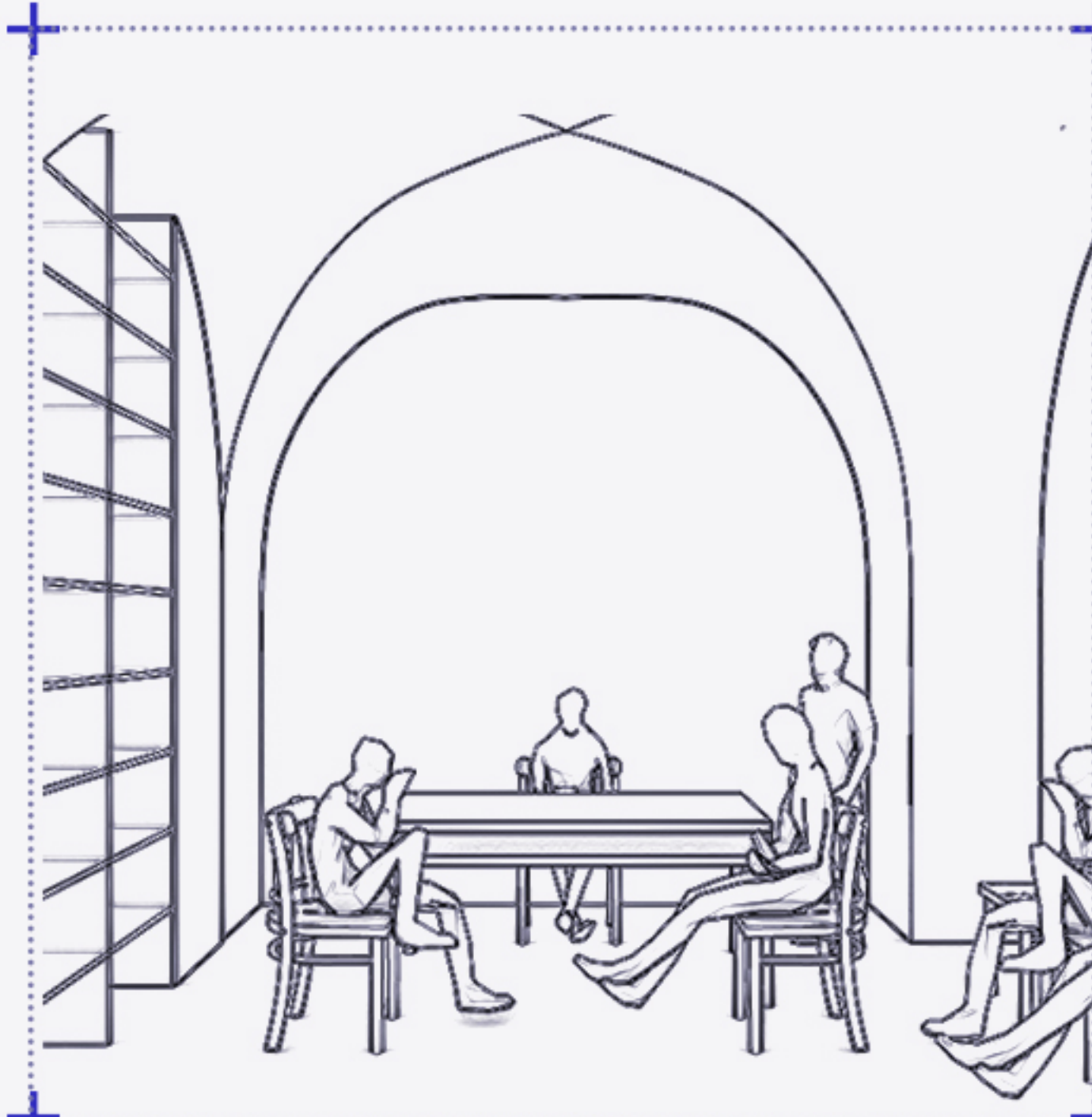

1

THE SOAP INDUSTRY HAS SURVIVED THROUGHOUT THE YEARS BY BEING PASSED DOWN FROM VENDORS TO THEIR OFFSPRING AS ITS COMMERCE AND ECONOMICS PROVIDE A MEANS FOR ITS SUSTENANCE.

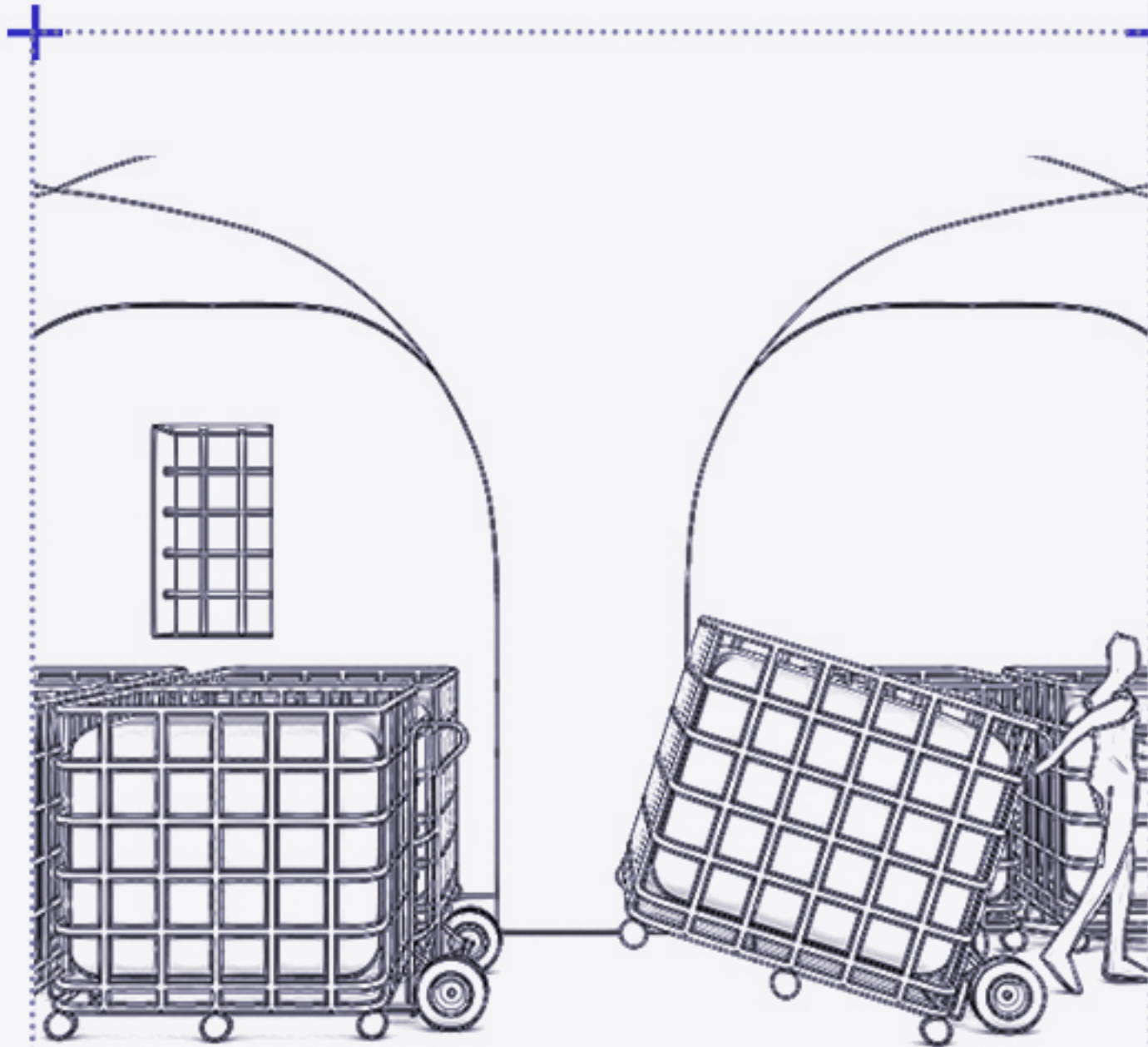

2

STORAGE SPACE

PRESERVATION OCCURS ,DURING THE OIL SEASON

(NOVEMBER TO DECEMBER)

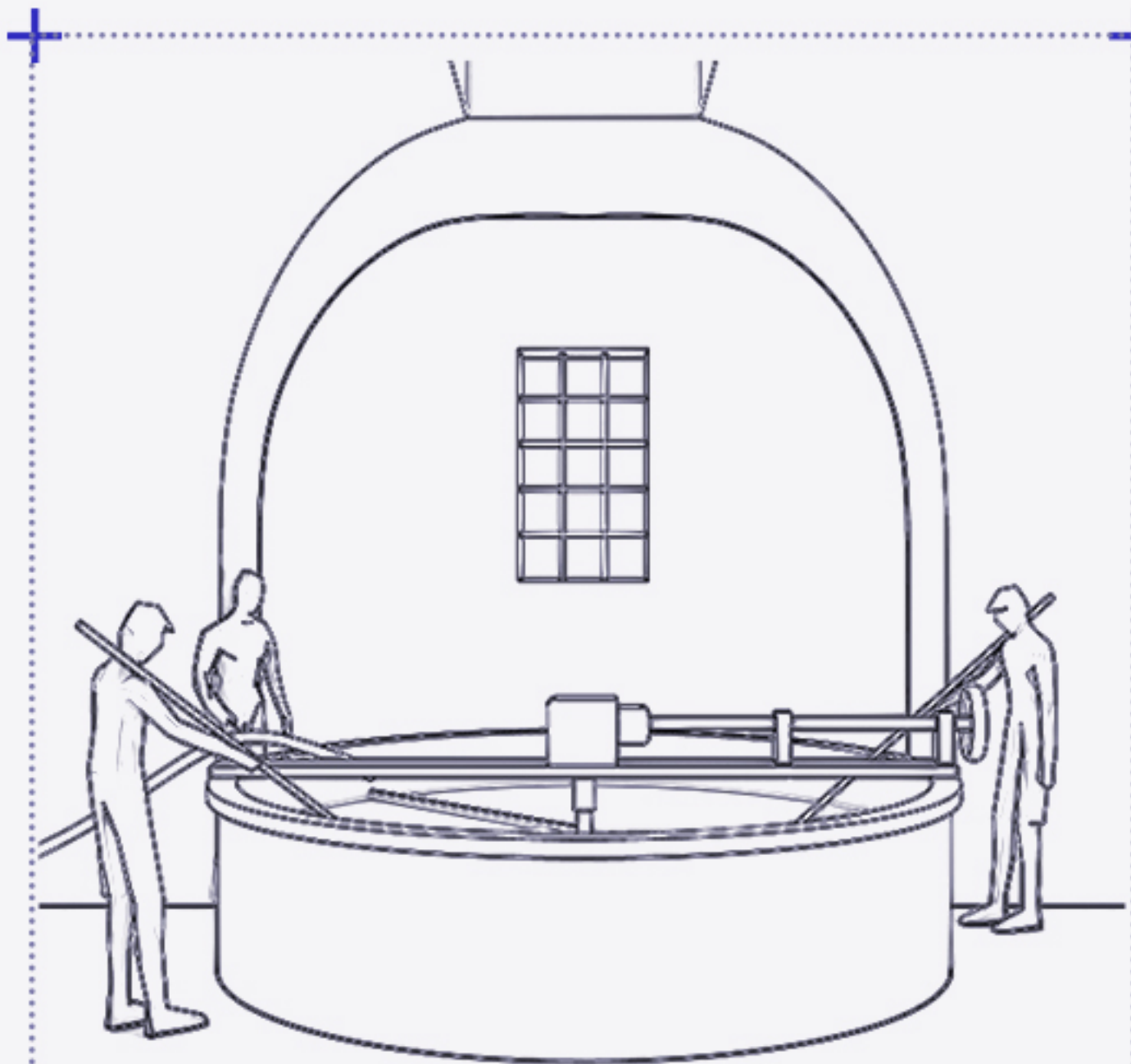

3

COOKING SPACE

IN NABLUS, THE OIL IS SUBSEQUENTLY HEATED IN A BIG VAT CONTAINING WATER, LYE, LAUREL OIL ,OLIVE OIL, BAKING SODA, AND WATER .

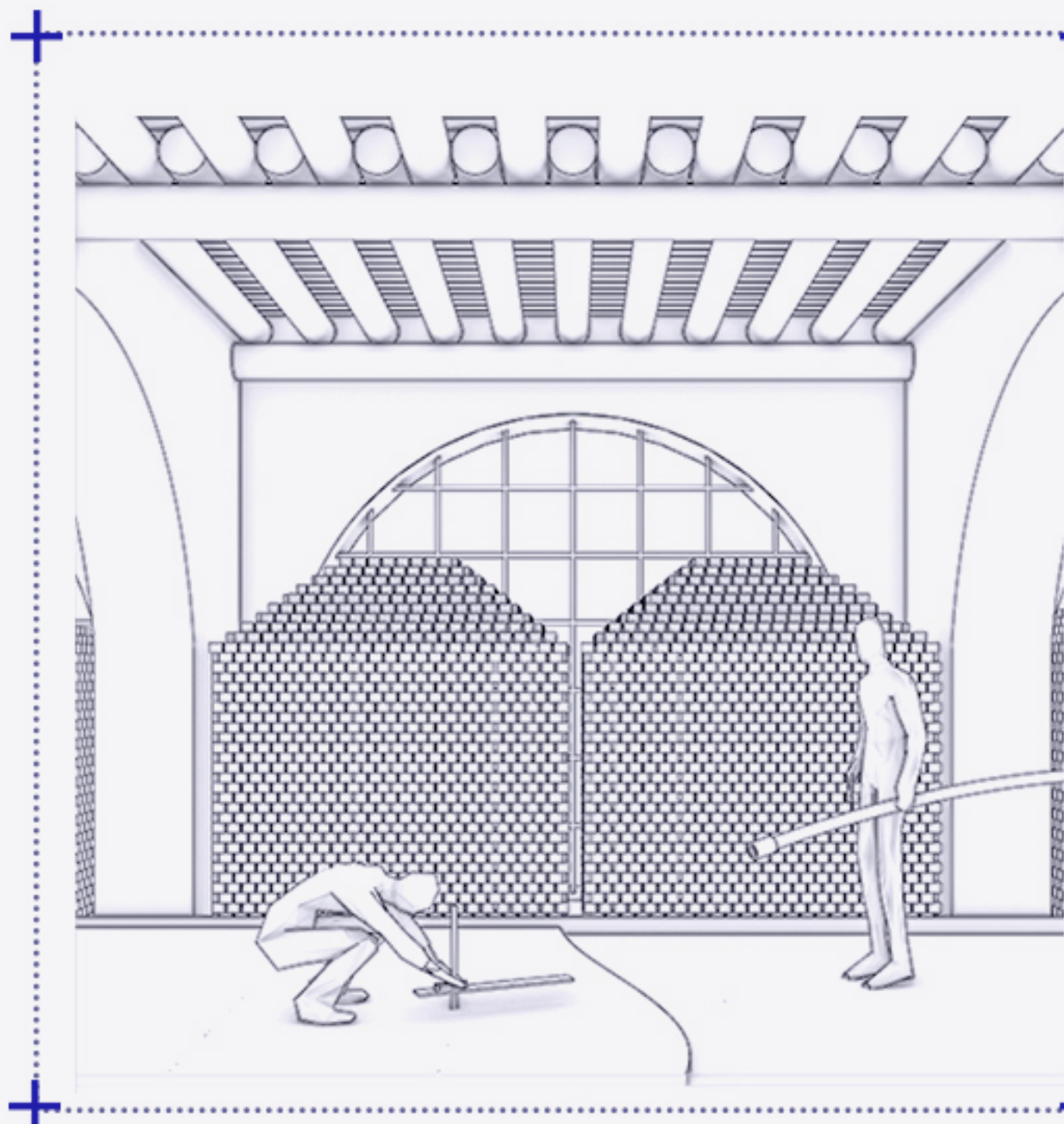

4

PREPARATION SPACE

WORKERS UNIFORMLY
DISTRIBUTE AND SMOOTH
THE LIQUID SHORTLY AFTER
POURING THE MIXTURE OVER
A BIG SHEET OF WAX.

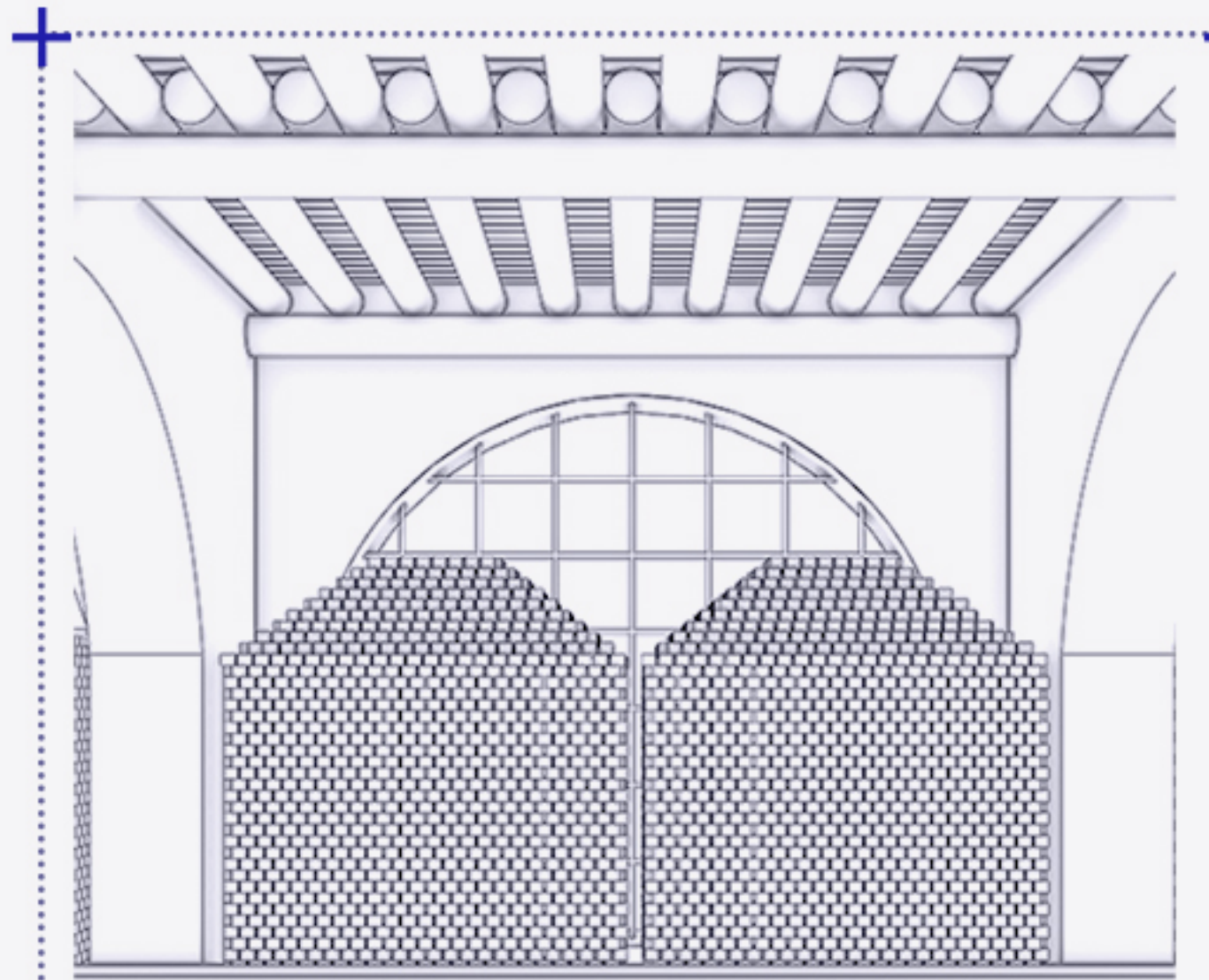

THE RESULTING MIXTURE
UNDERGOES A COOLING
PROCESS FOR A DAY. ONCE IT
HAS COOLED, IT IS SLICED BY
HAND.

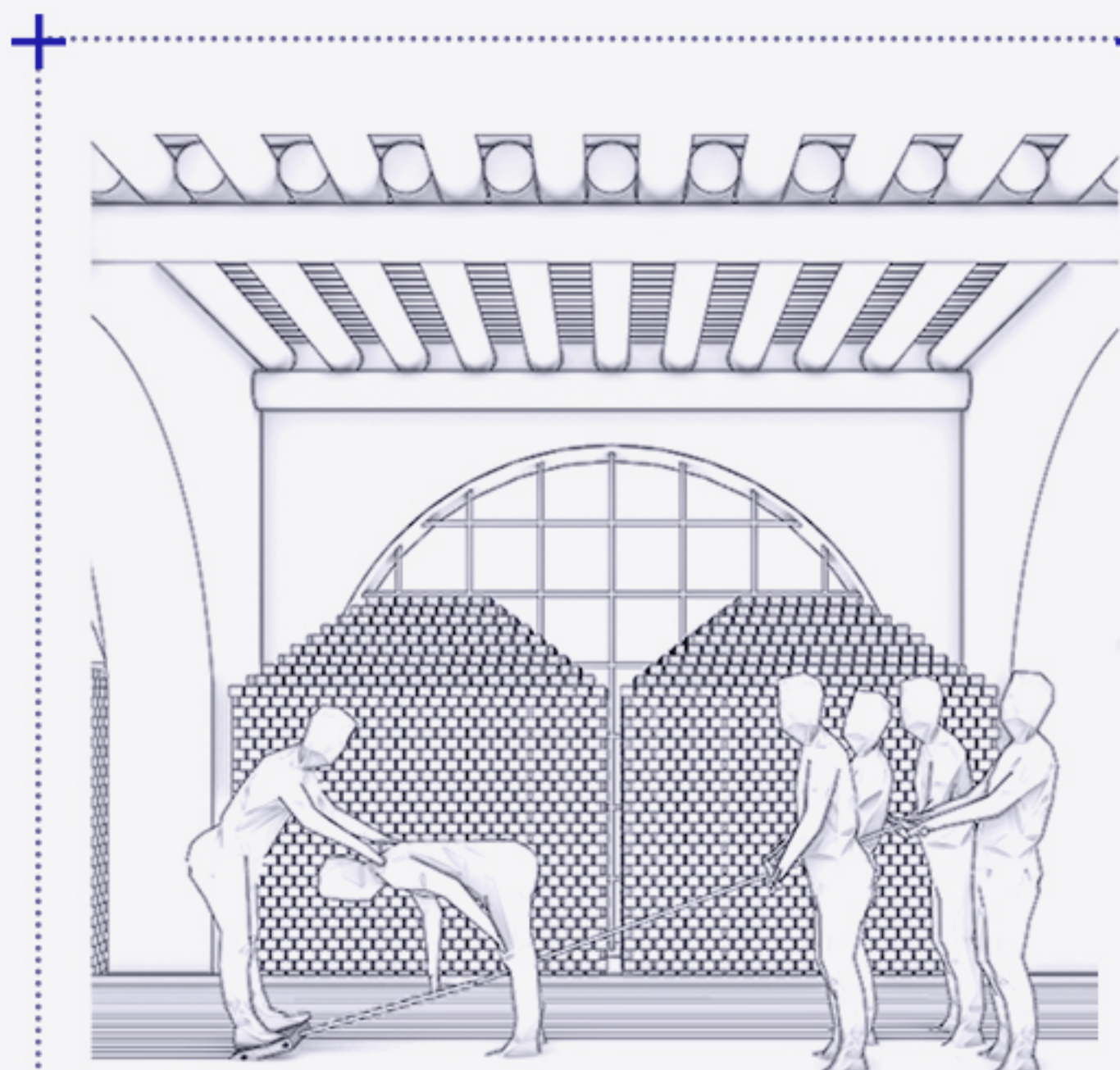

THE OUTLINES OF THE SOAP
ARE TRACED FOR CUTTING IN
NABLUS USING A THREAD
AND A RED DYE.

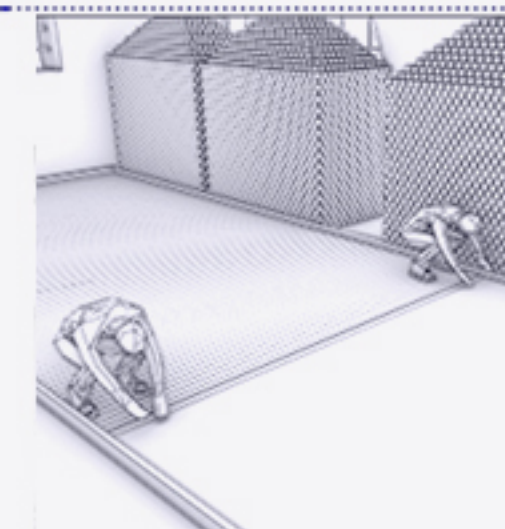
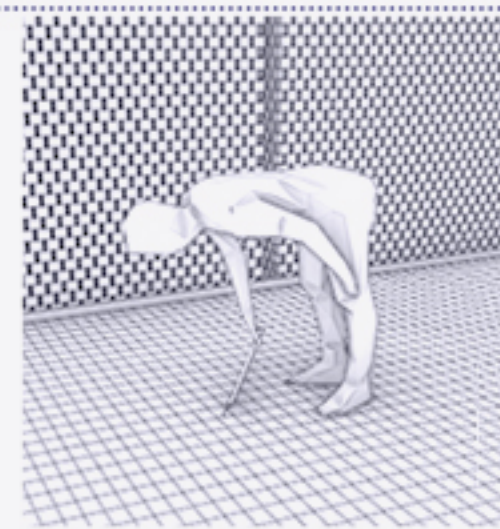

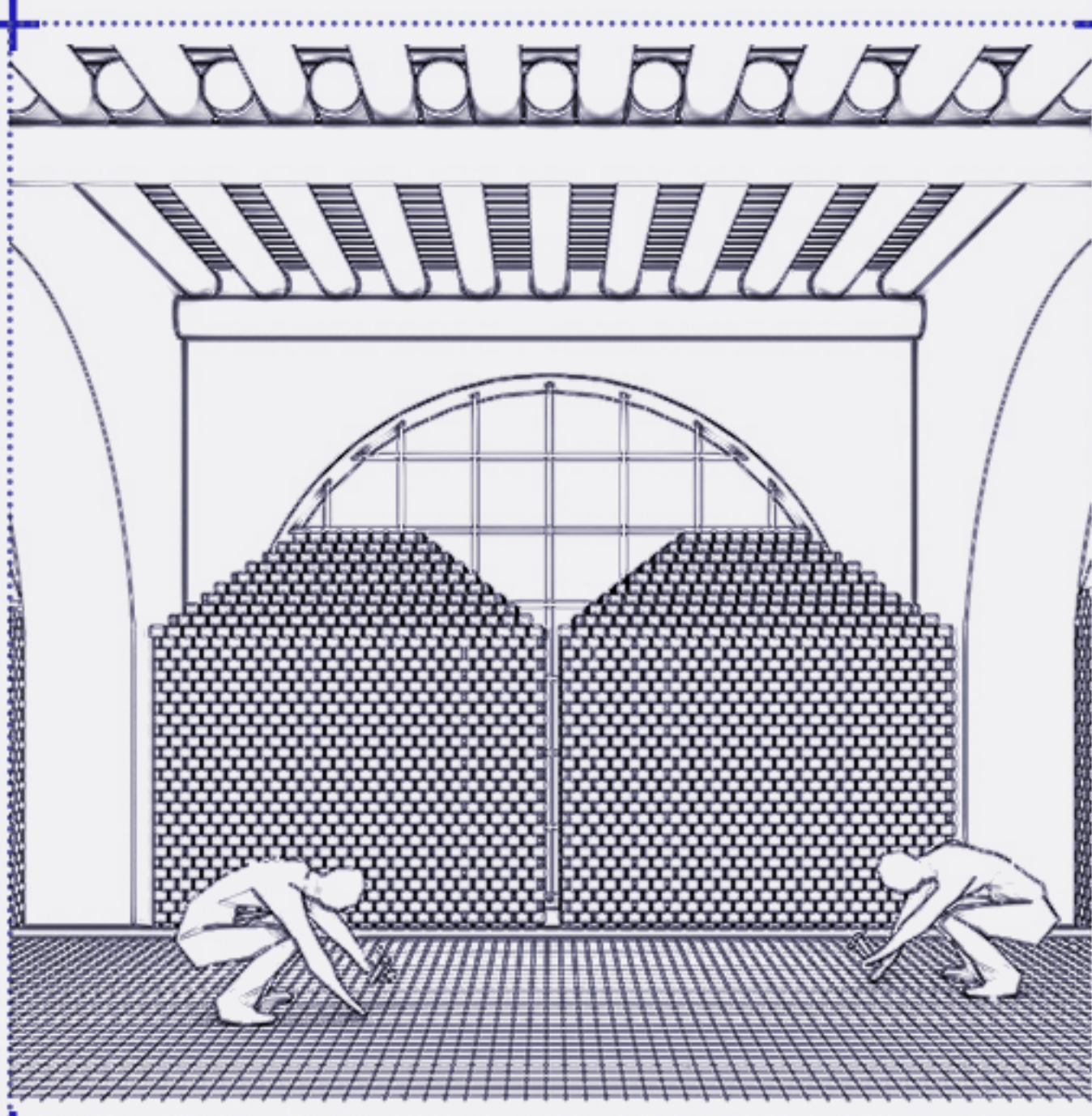

THE BRAND'S LOGO IS THEN
MANUALLY IMPRINTED ON
EACH BLOCK WITH HAMMERS.

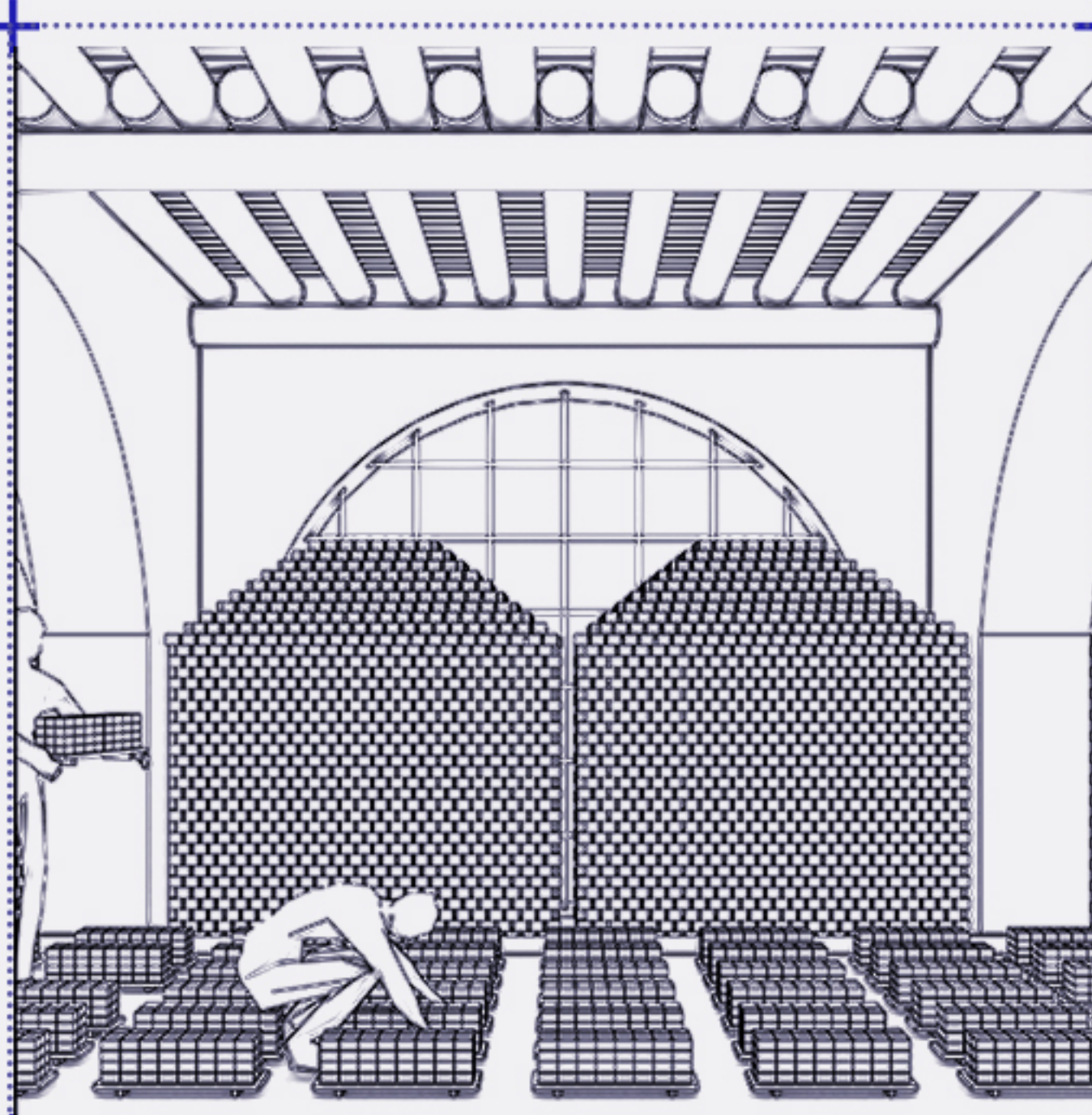

THE SOAP BARS ARE
STACKED AND THEN LEFT TO
DRY.

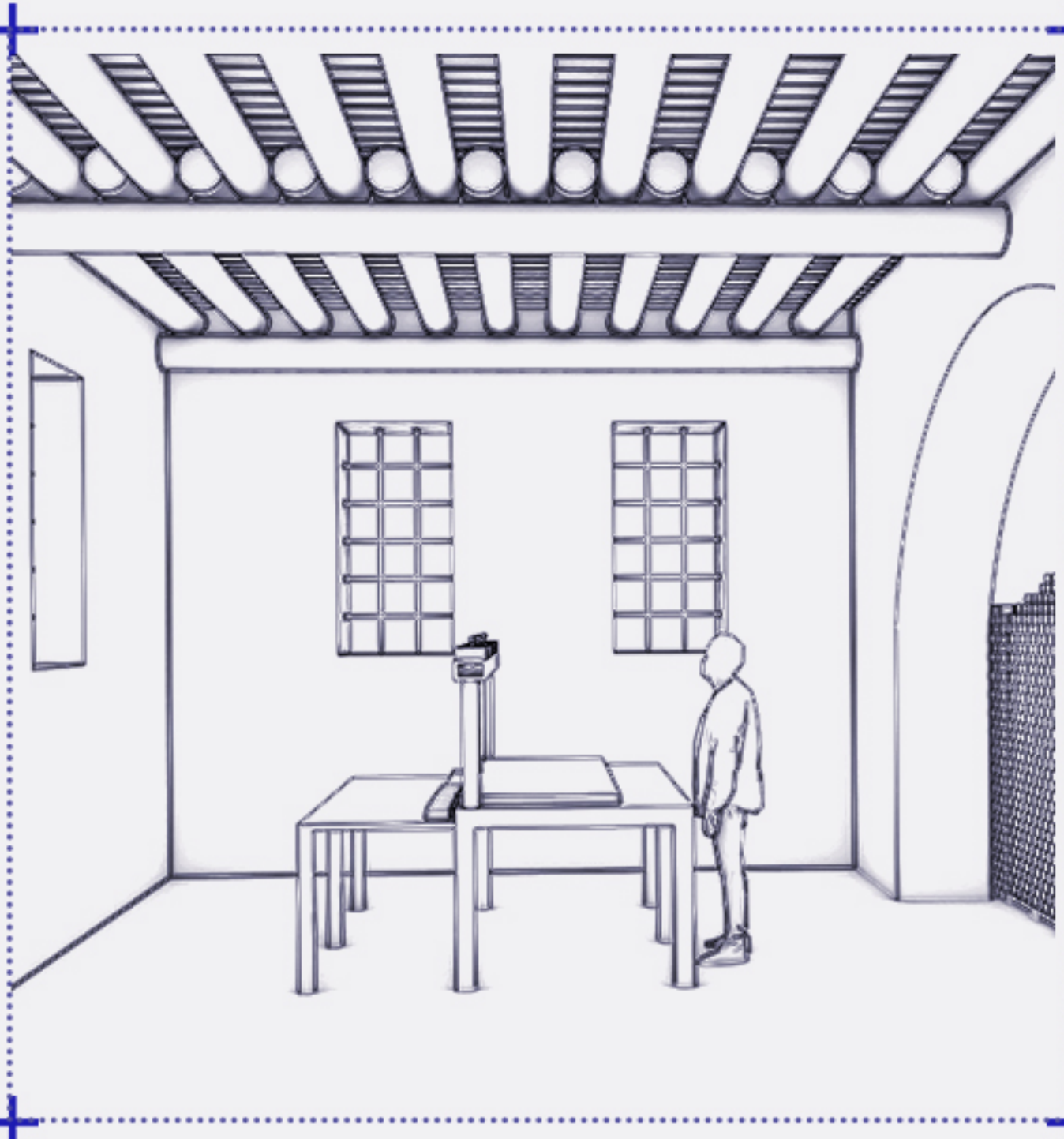

5

ALTERNATIVE

ANOTHER METHOD OF
CUTTING IS TO CREATE
ANOTHER PRODUCT THAT
WE MIGHT COME ACROSS IN
VARIOUS FACTORIES.

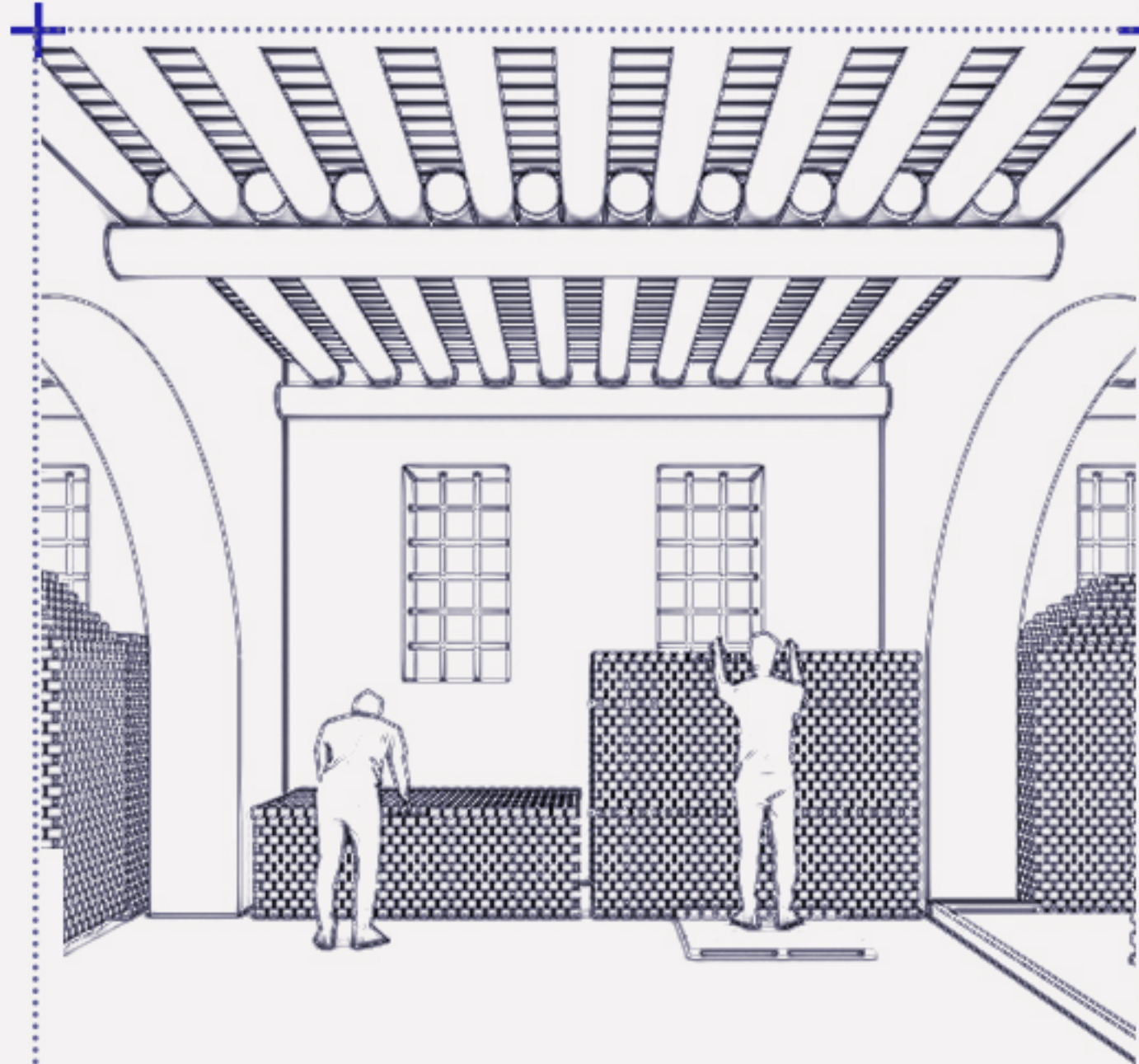

6

DRYING SPACES

TO AID IN THE THE DRYING PROCESS, THE SOAP BARS ARE STACKED ONTO STRUCTURES; THE DRYING PROCESS TAKES APPROXIMATELY SIX TO TWELVE MONTHS.

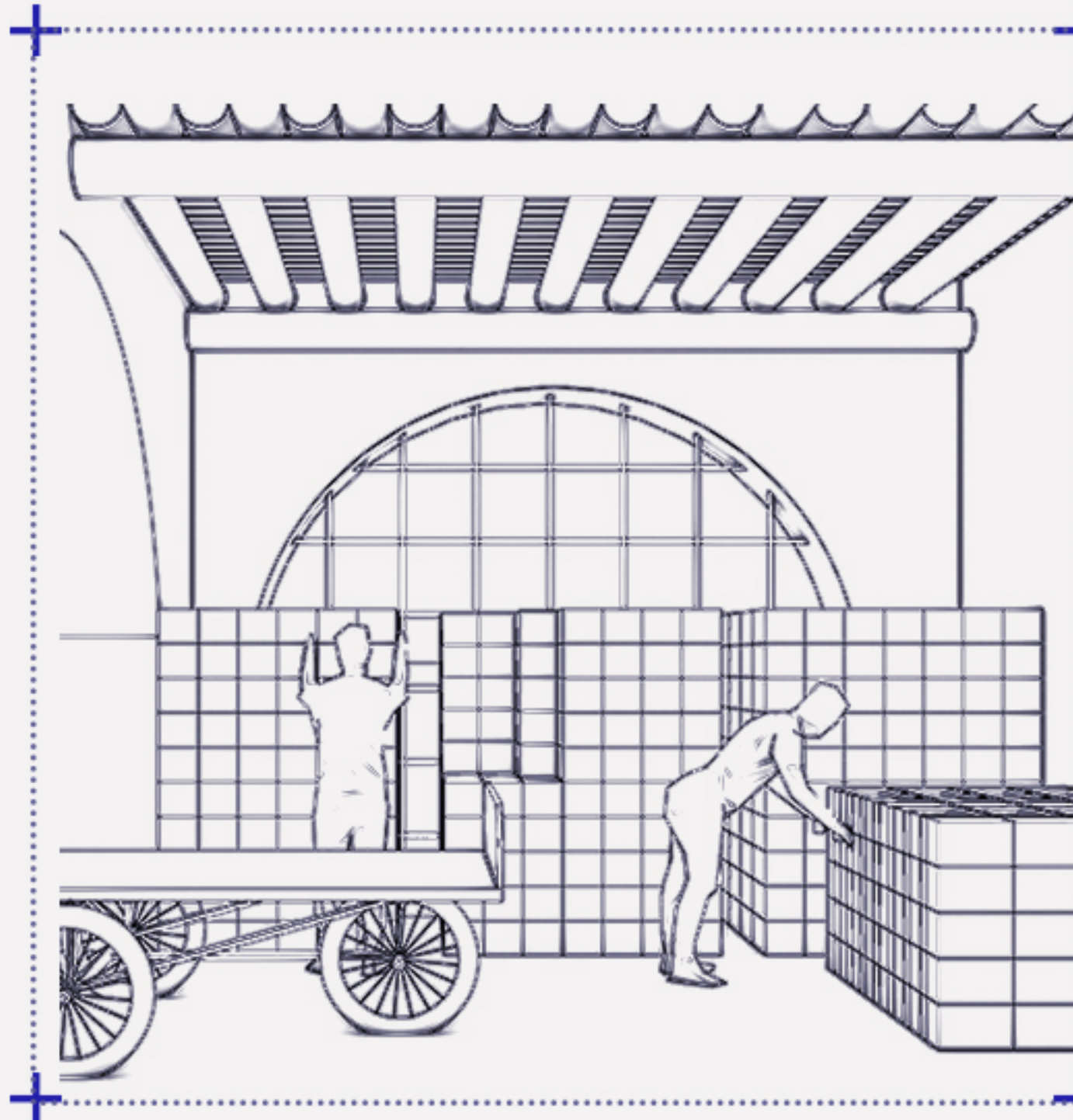

7

PACKAGING SPACES

OCCURS AT ANY TIME OF THE YEAR.

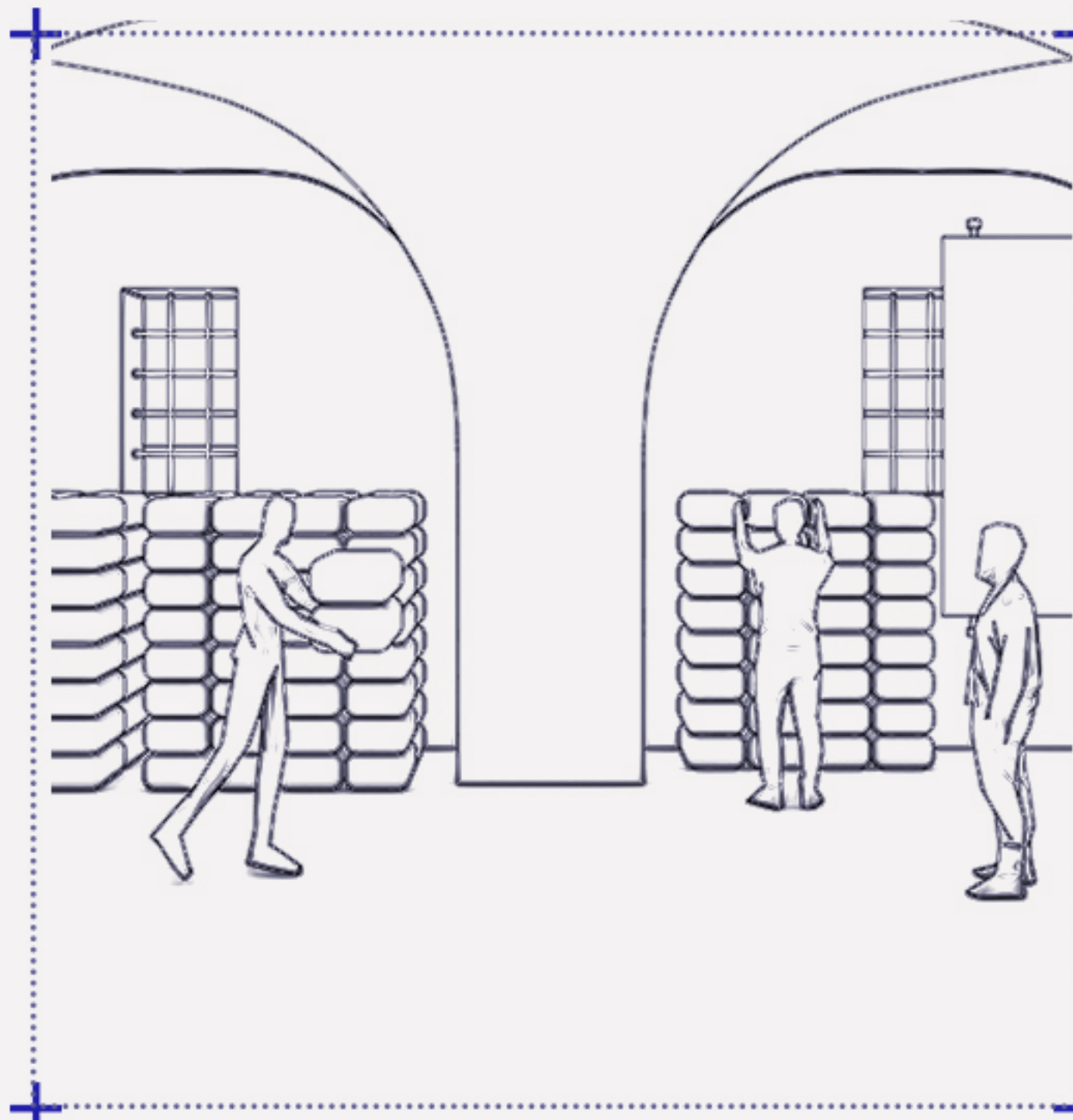

8

EXPORTING SPACES

TAKES PLACE THROUGHOUT THE YEAR.

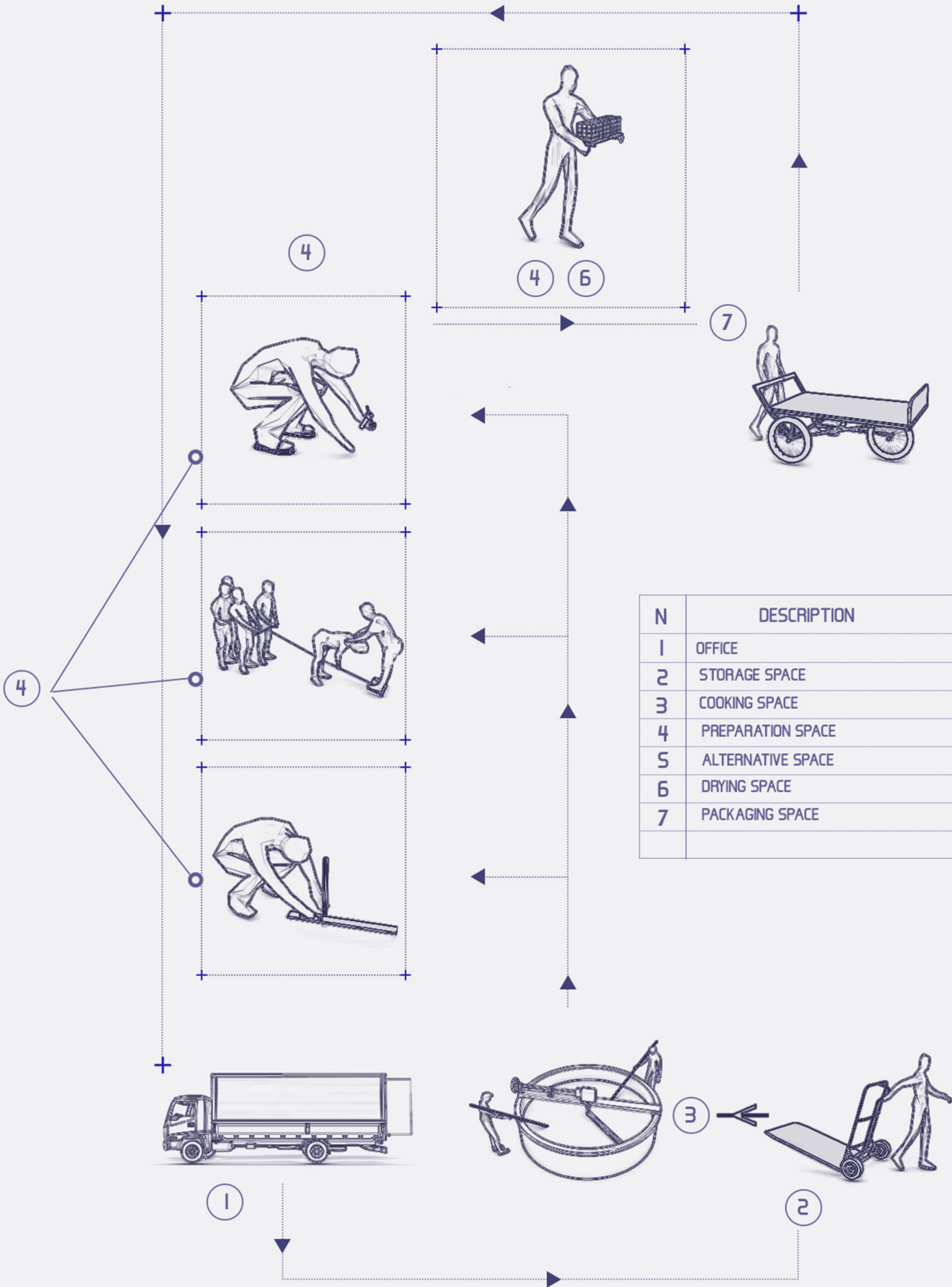

N	DESCRIPTION
1	OFFICE
2	STORAGE SPACE
3	COOKING SPACE
4	PREPARATION SPACE
5	ALTERNATIVE SPACE
6	DRYING SPACE
7	PACKAGING SPACE

+ TANNOUR | DESIGN EXPLORATIONS +

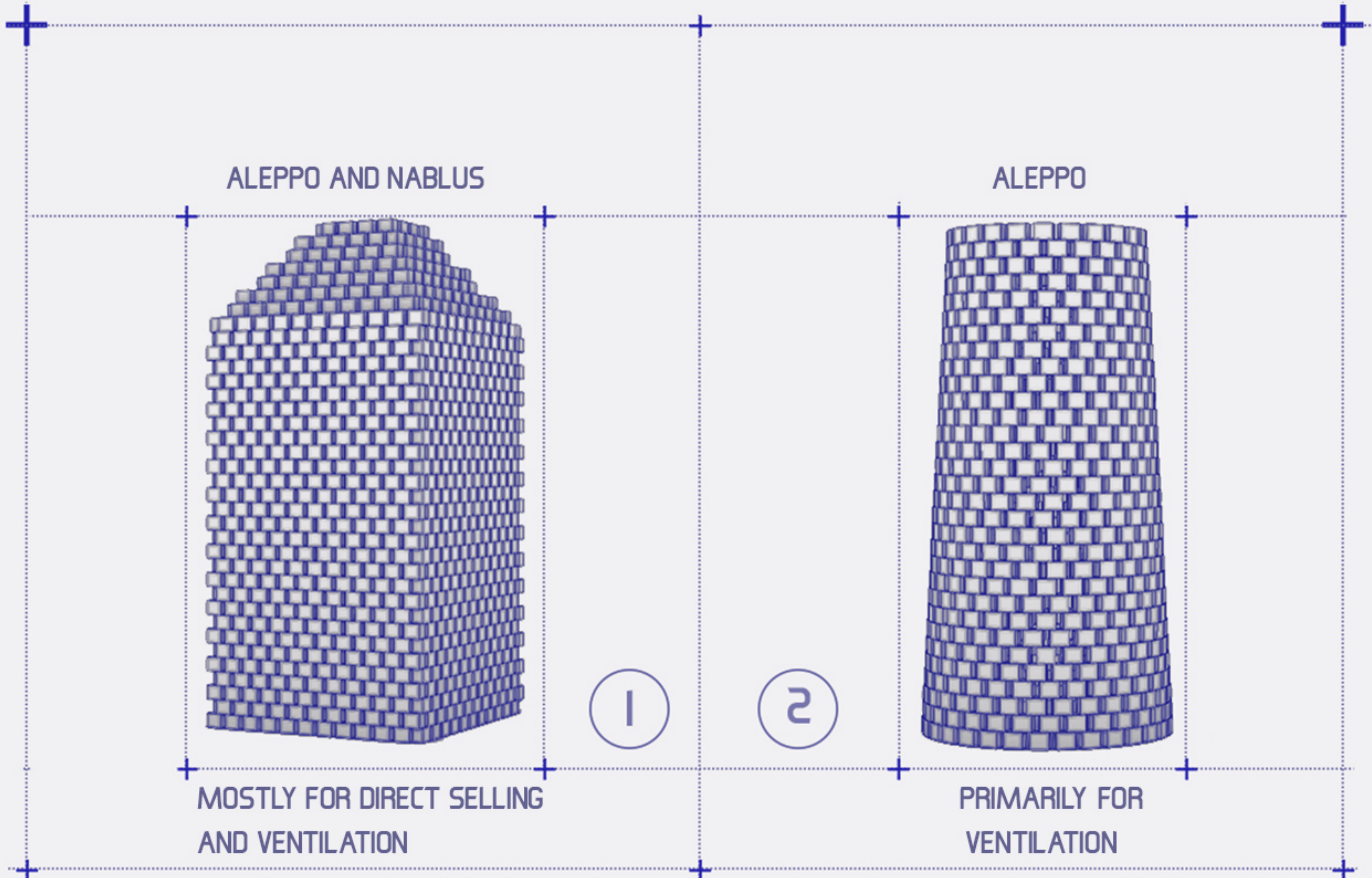

DISTINCTIVE FORMATIONS

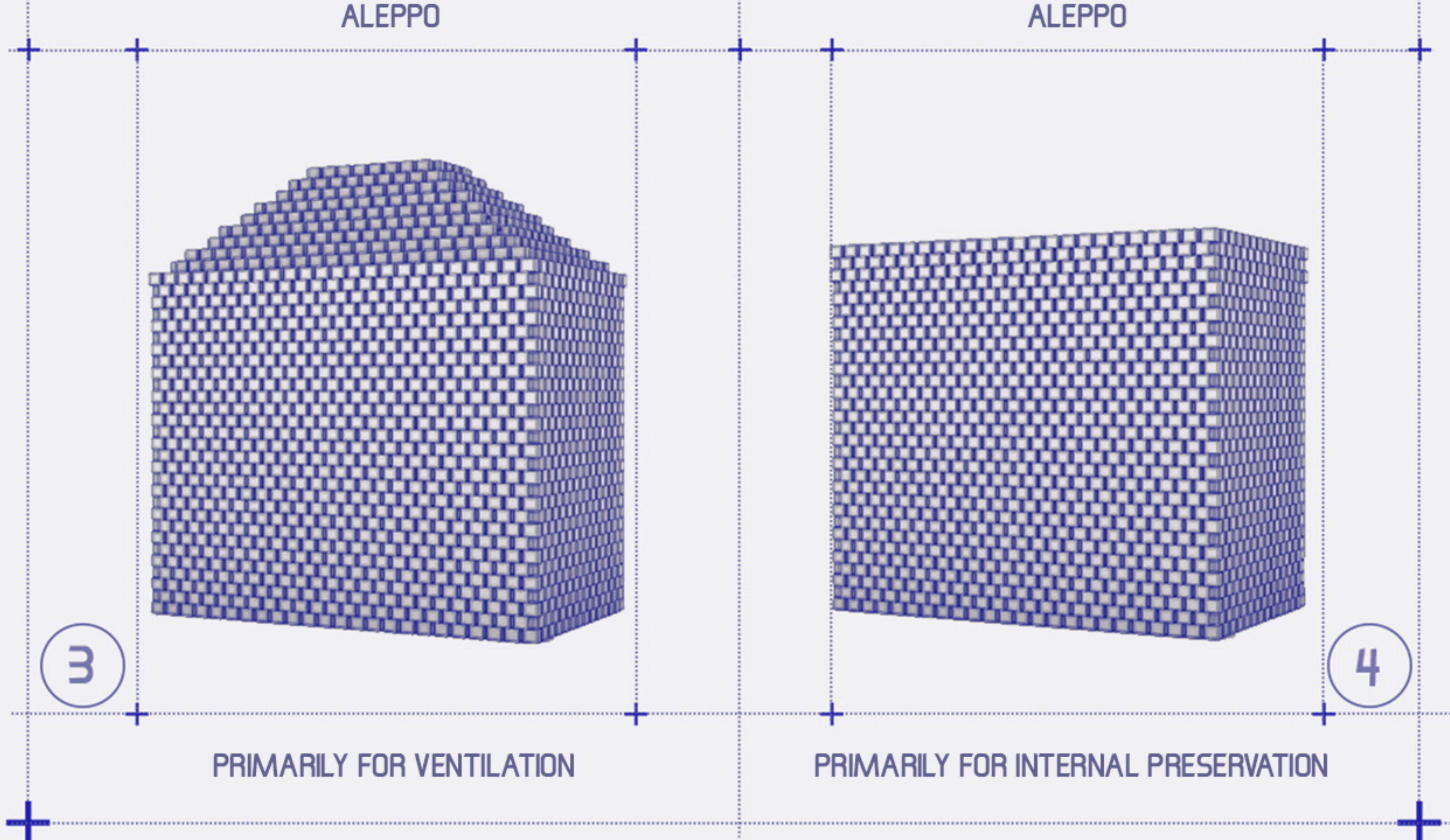

FACTORS CONTRIBUTING IN THE DECLINATION OF THE SOAP INDUSTRY

- PRICE HIKES REGARDING CONTAINERS AND SHIPMENT.
- THE CONSTRAINTS ON ATTAINING BANK TRANSACTIONS AMID THE WAR .
- THE EXORBITANT RATES OF FUEL AND THE UNAVAILABILITY OF ELECTRICITY.
- THE WAR'S DEVASTATION ON MANUFACTURING SECTORS .
- RESTRICTIONS OF THE EXPORTATION OF SOAP.
- A DECREASE IN SOAP DEMAND AMONG PALESTINIANS AS A RESULT OF ITS EXPENSIVE PRICE .

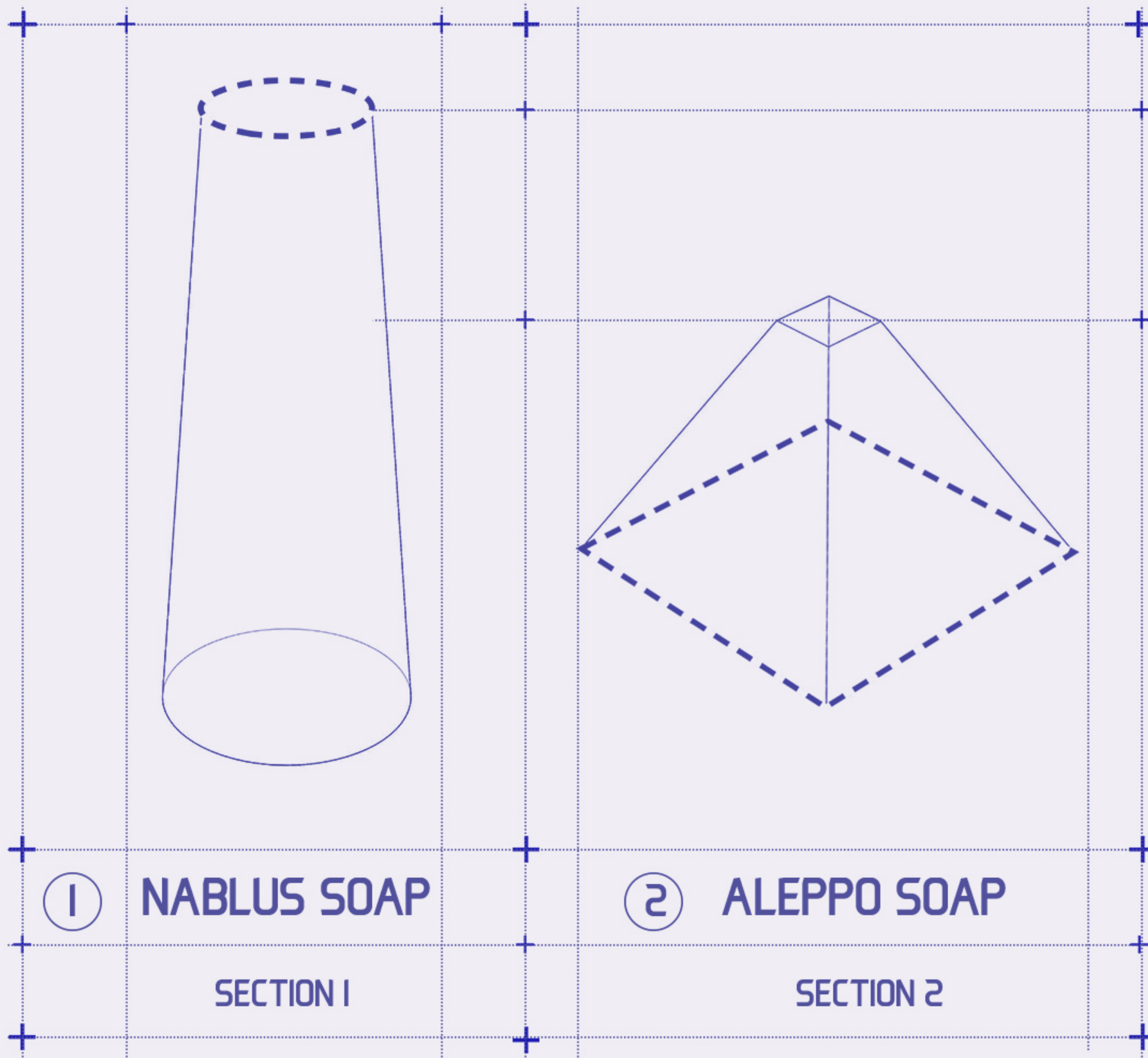

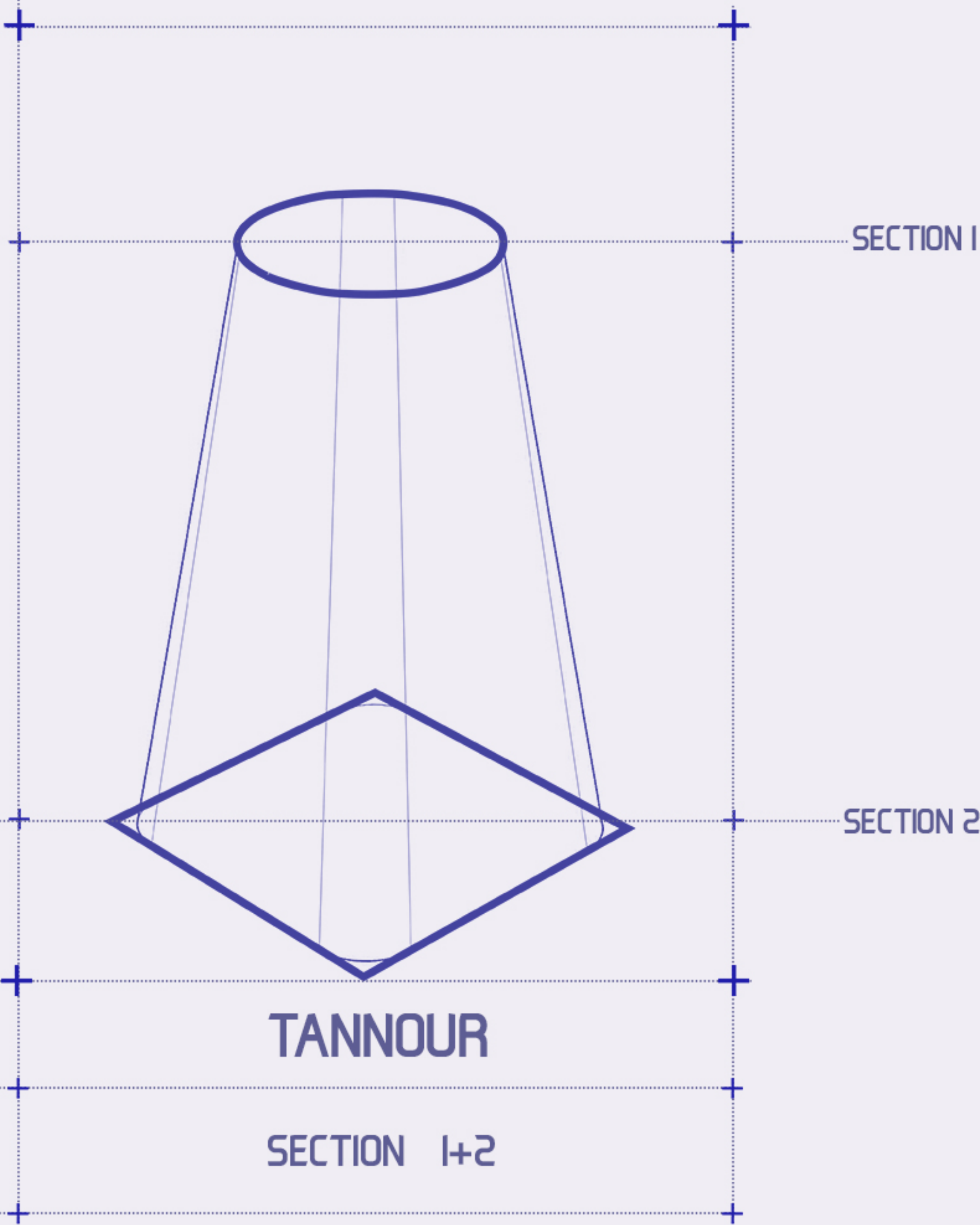

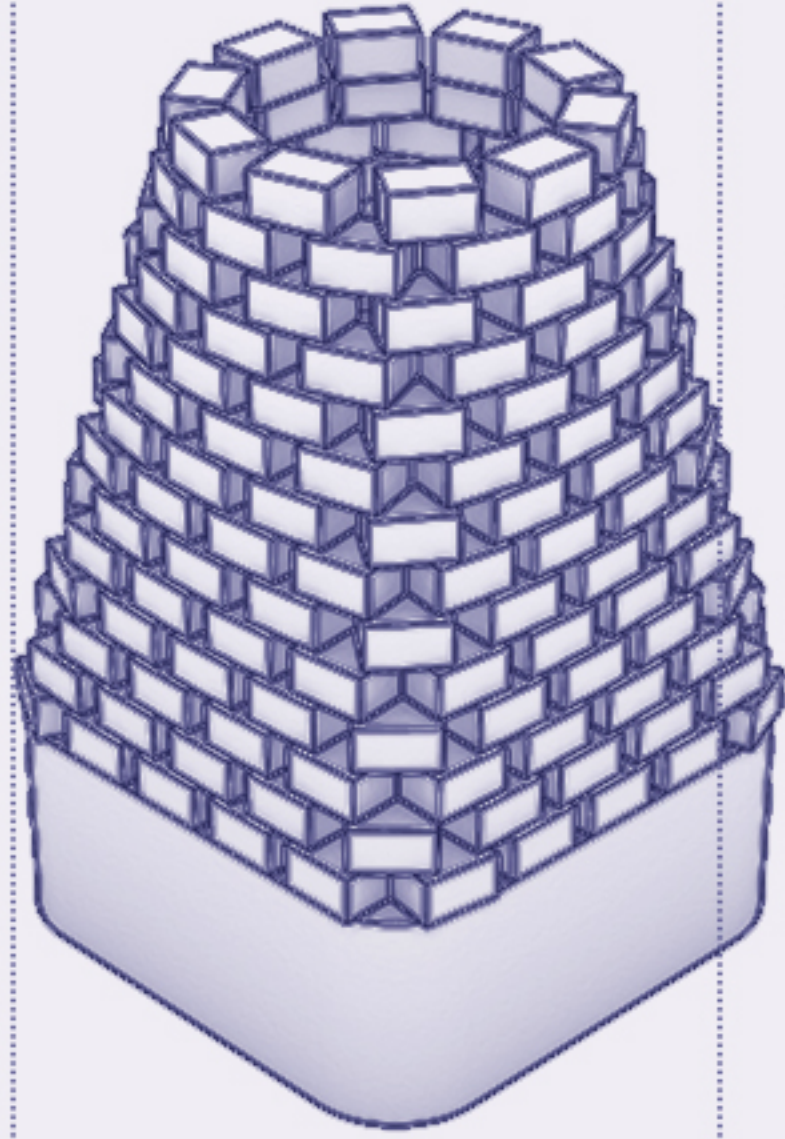

1

RECTANGLE EDGE 45
 CIRCLE DIAMETER 29
 HEIGHT 55

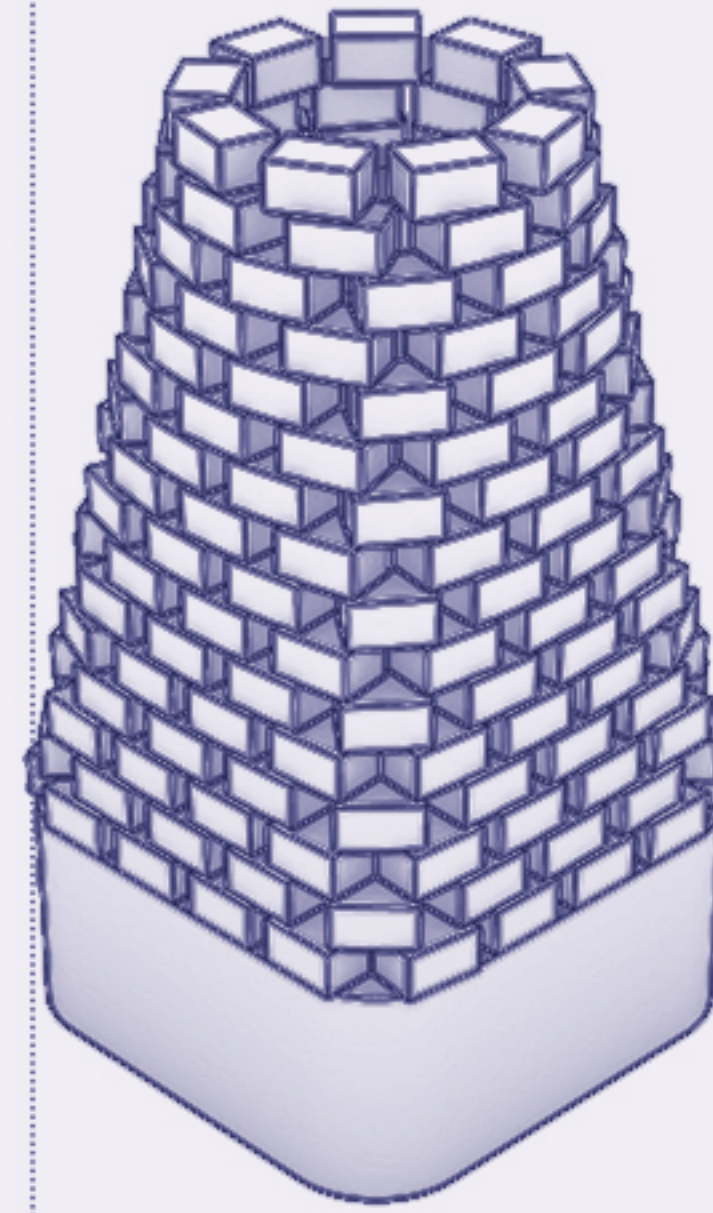

2

RECTANGLE EDGE 41
 CIRCLE DIAMETER 27
 HEIGHT 60

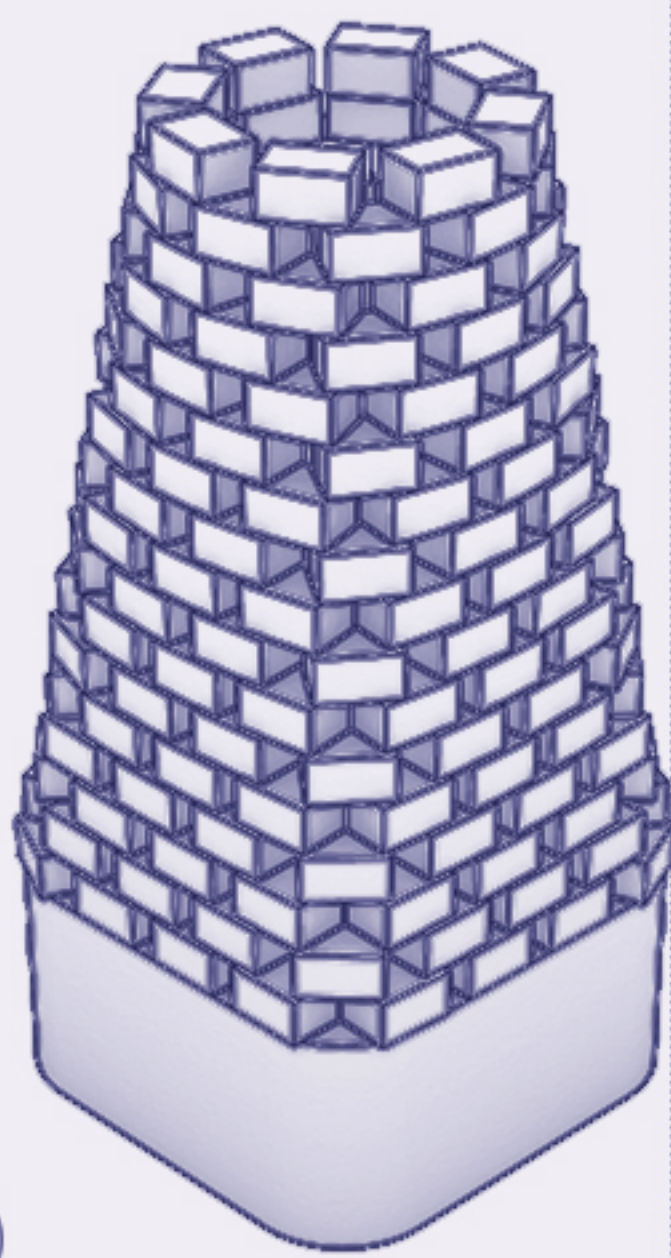

3

RECTANGLE EDGE 38
 CIRCLE DIAMETER 25
 HEIGHT 65

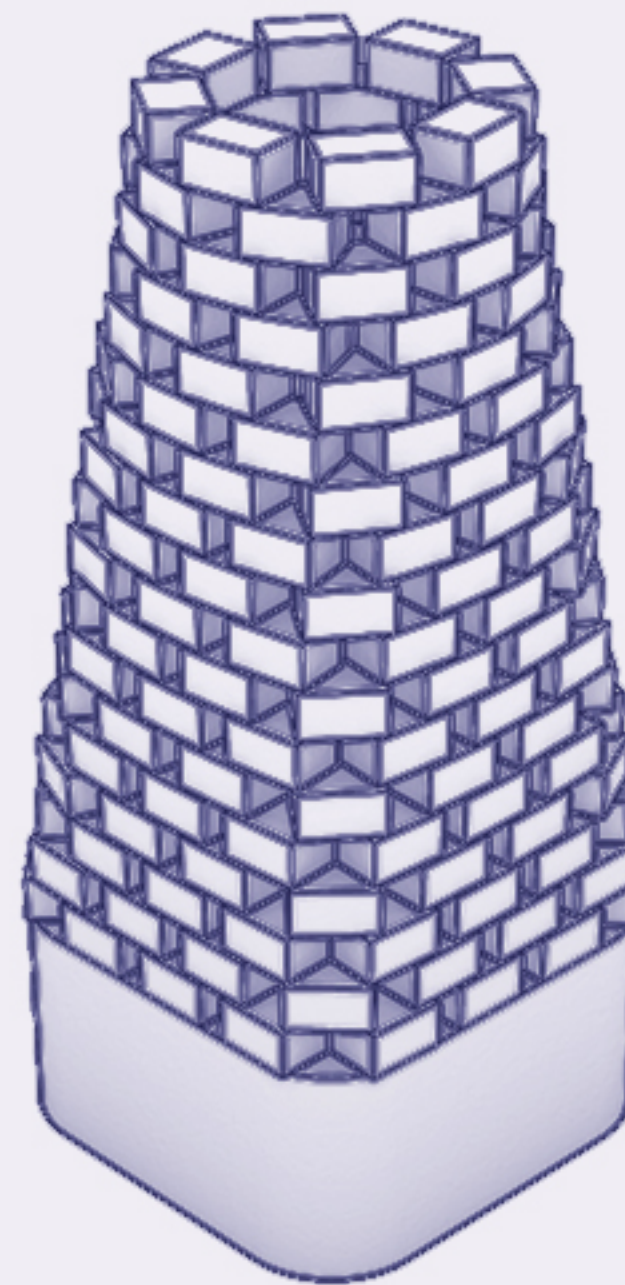

4

RECTANGLE EDGE 36
 CIRCLE DIAMETER 23
 HEIGHT 70

TOTAL SOAP COUNT IN EACH – 200

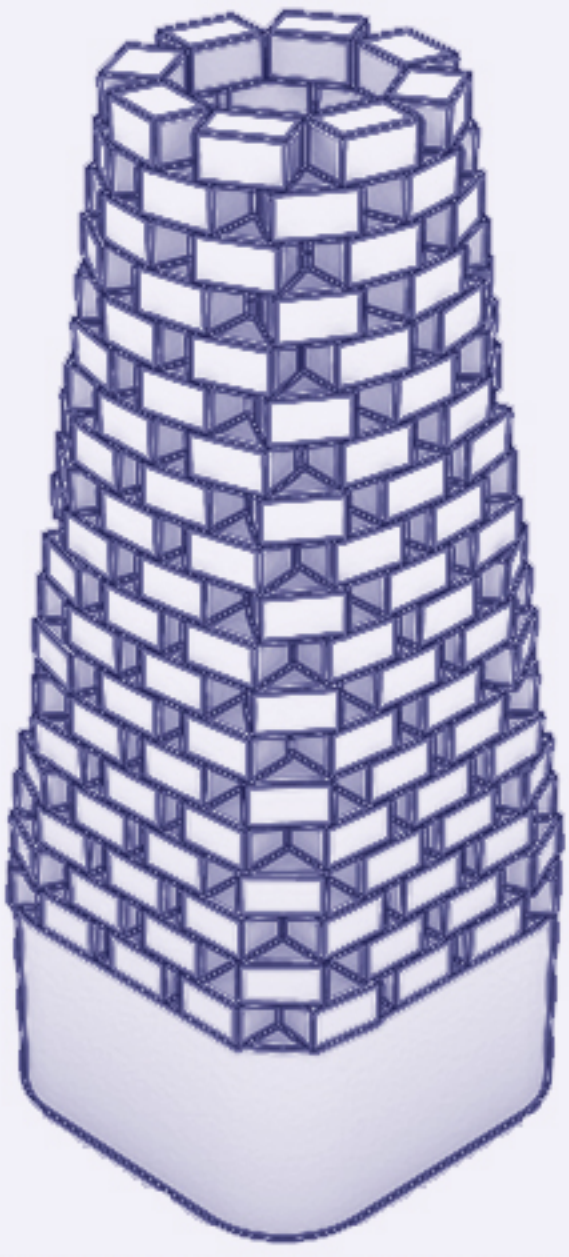
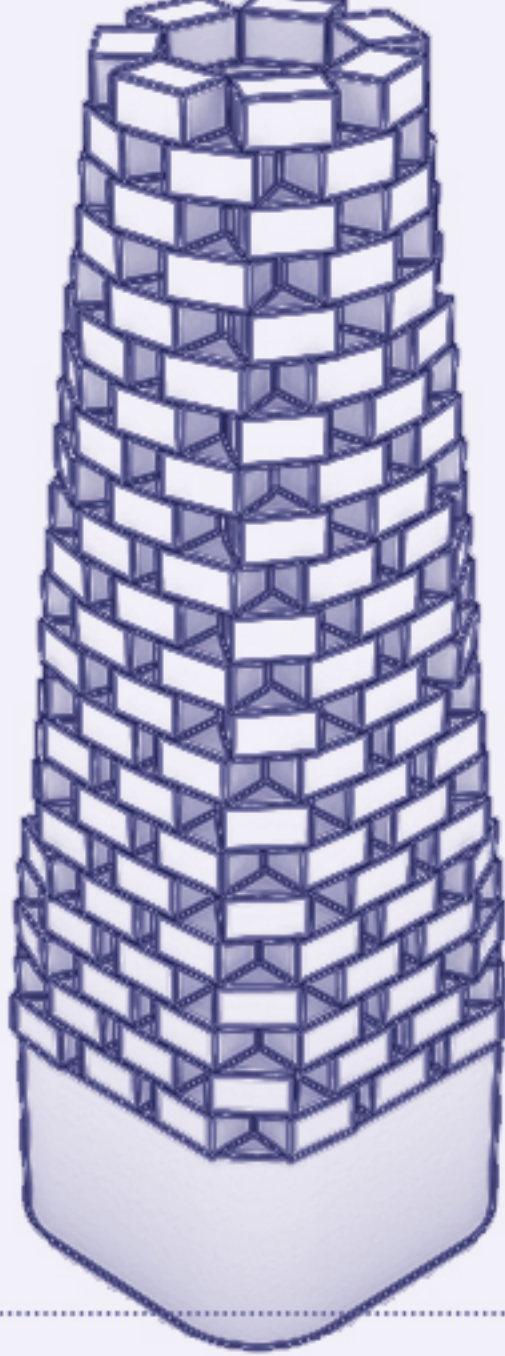
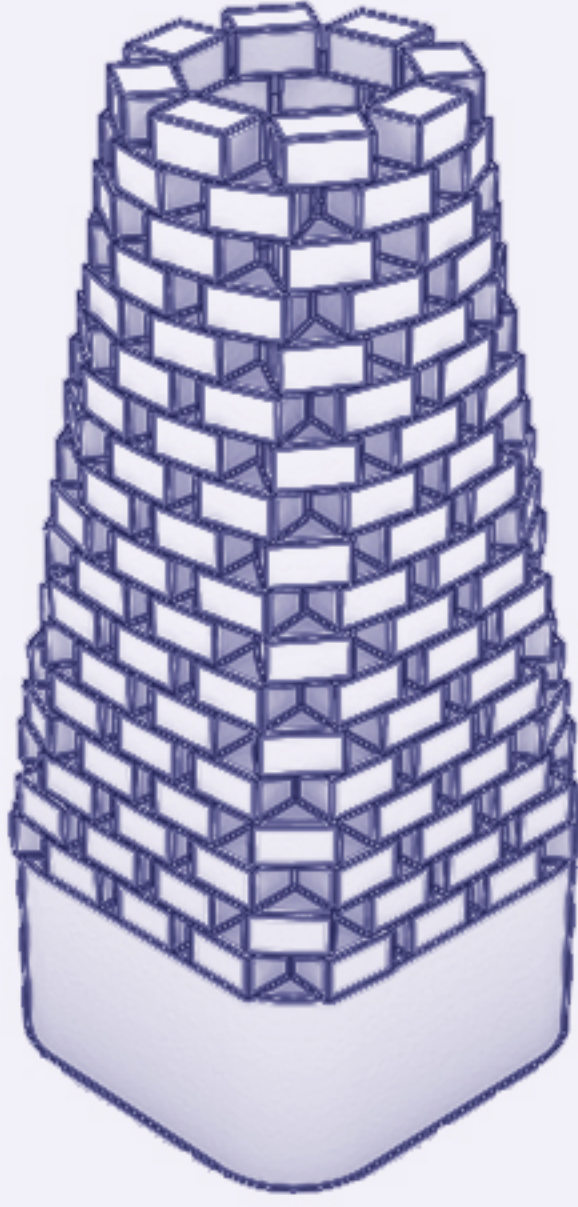
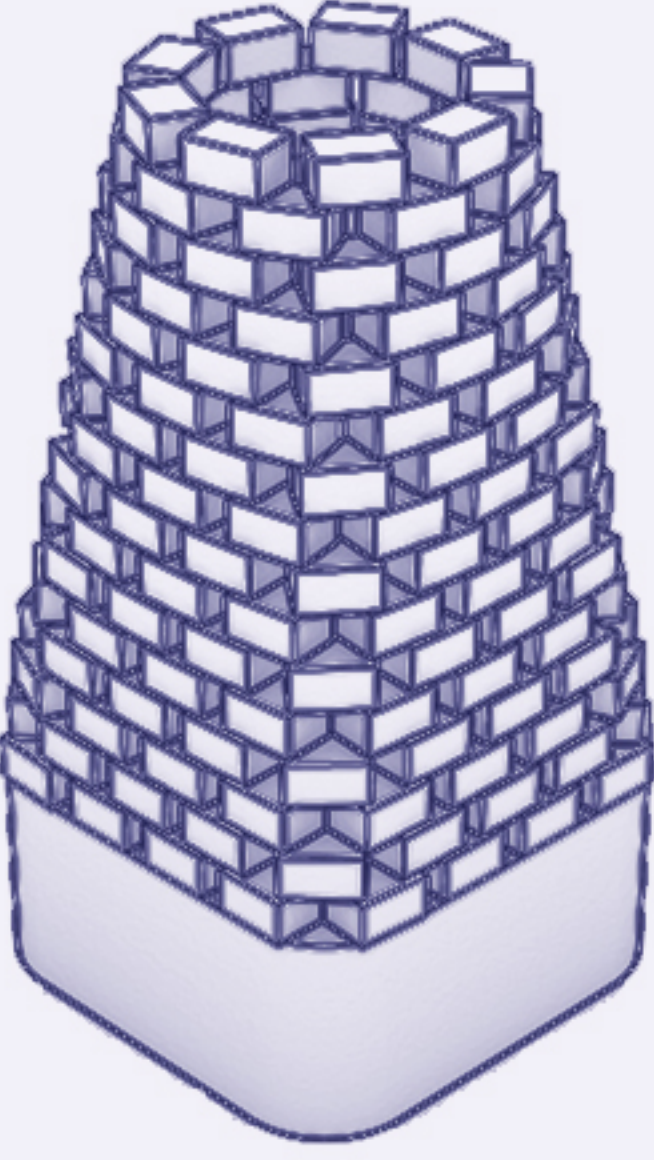
<p>⑤</p> 			 <p>⑥</p>
	<p>RECTANGLE EDGE 34 CIRCLE DIAMETER 22 HEIGHT 75</p>		<p>RECTANGLE EDGE 30 CIRCLE DIAMETER 20 HEIGHT 86</p>
	<p>⑦</p>		 <p>⑧</p>
	<p>RECTANGLE EDGE 35 CIRCLE DIAMETER 23 HEIGHT 71</p>		<p>RECTANGLE EDGE 40 CIRCLE DIAMETER 26 HEIGHT 63</p>

TOTAL SOAP COUNT IN EACH – 200

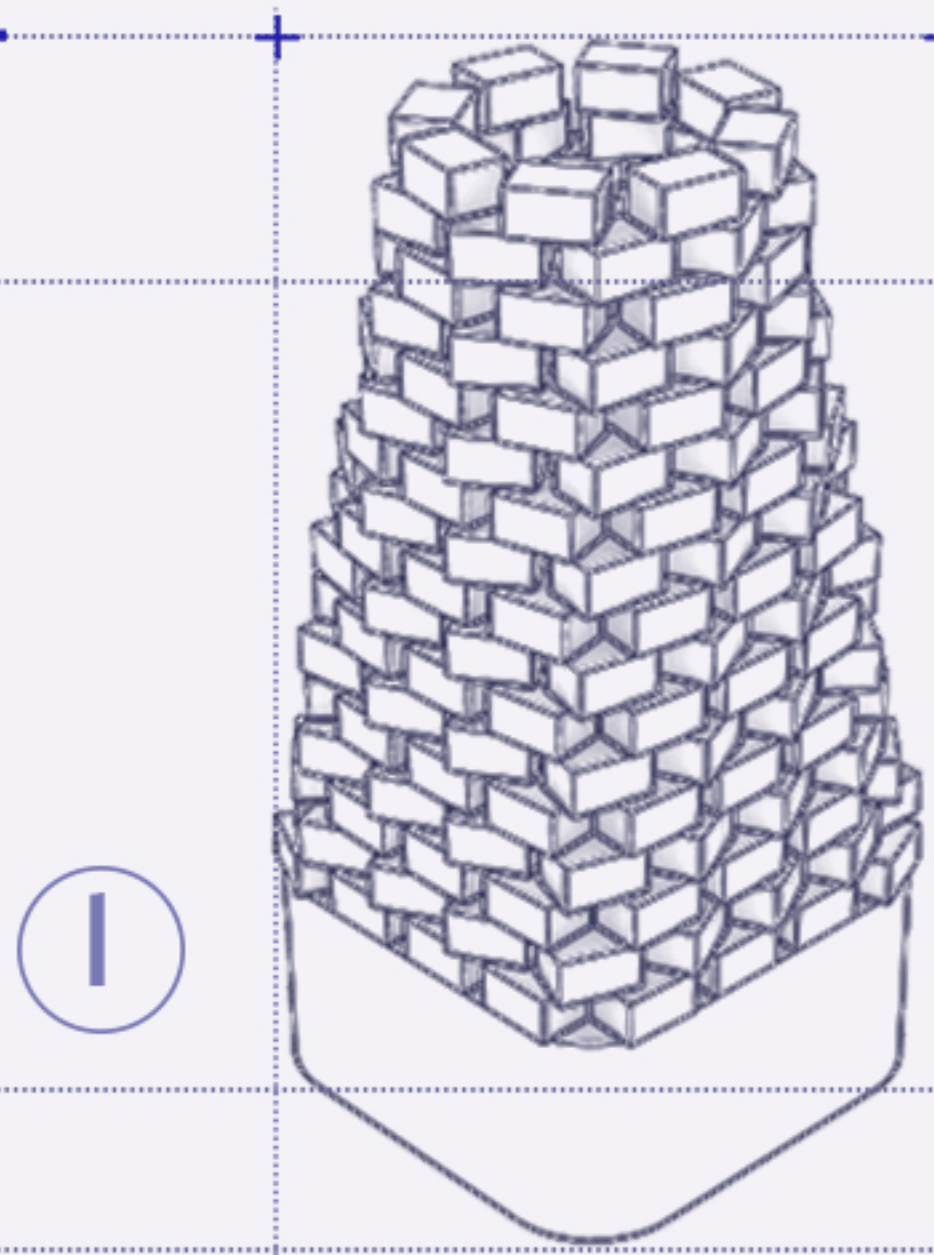

RULER

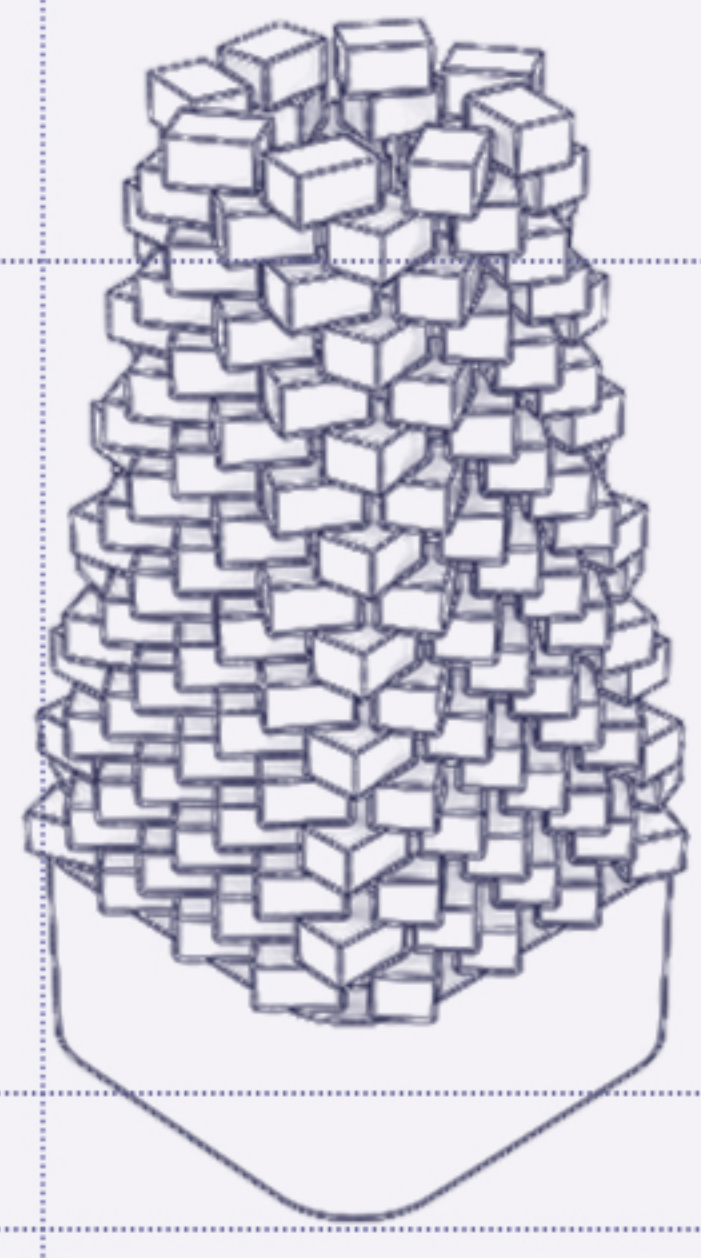

CHOSEN

RULER

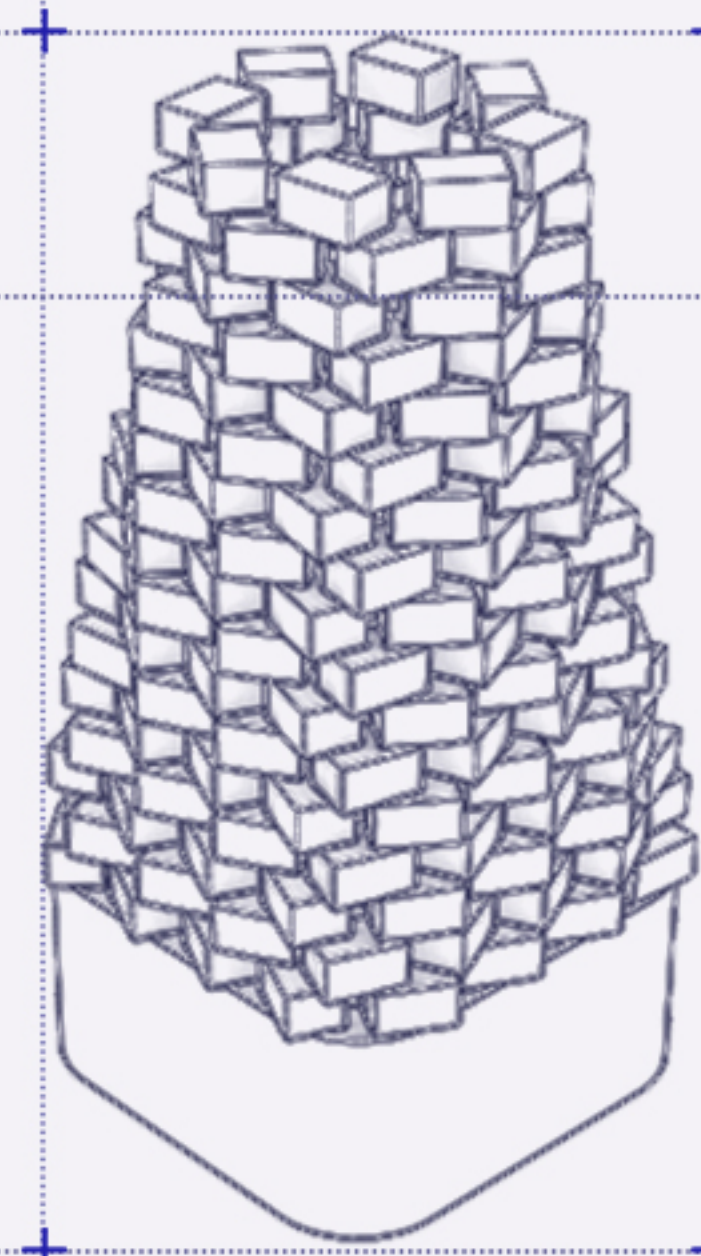

RULER

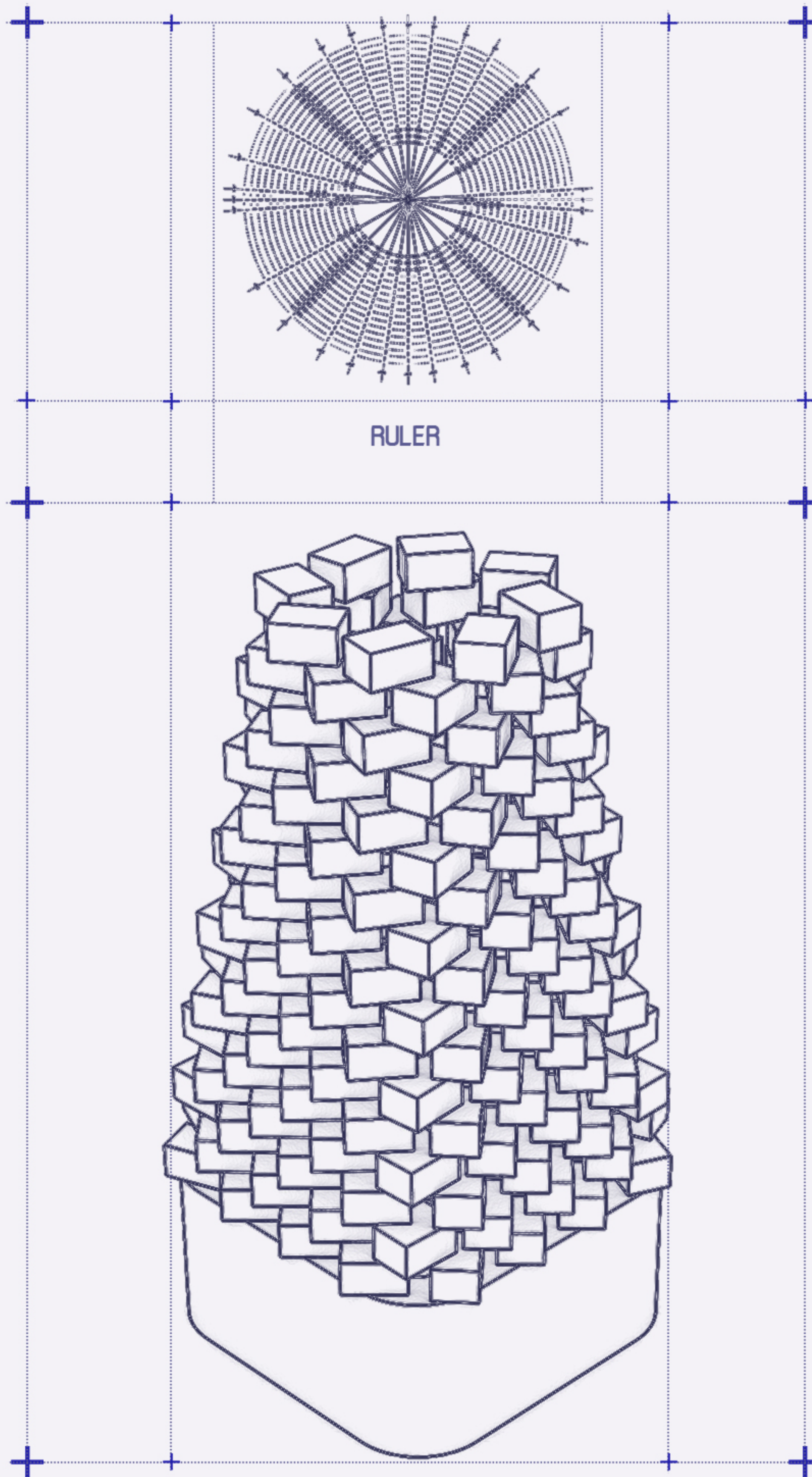

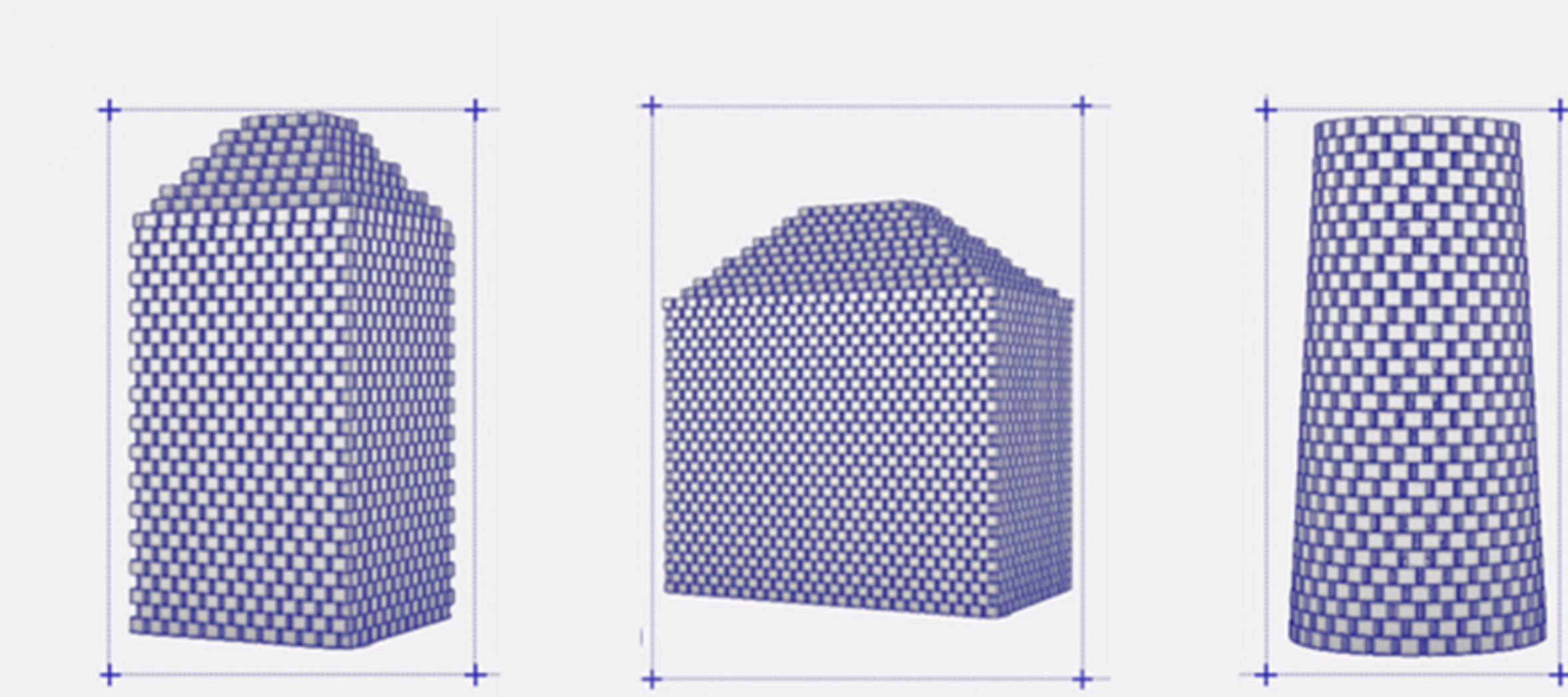

WESAM ALASALI | NADI ABUSAADA

IWLAB

MARAH SHARABATI | JOELLE DEEB | AHMAD SALAH